



WATER CLEANING & BLASTING PRODUCT CATALOGUE

2026

TABLE OF CONTENTS 1

INTRODUCTION..... 2

 WATER CLEANING & BLASTING 3

 SAFETY GUIDE & DISCLAIMERS 4

 INDEX..... 5

HOSES

 GOLDENBLAST..... 9

 GOLDENBLAST/PLUS 10

 GOLDENBLAST/SIX..... 11

 ISOJET/28 (BLUE) 12

 ISOJET/28 (BLACK) 13

 ISOJET/28 (GREY) 14

 ISOJET/28 PLUS (BLUE) 15

 ISOJET/28 PLUS (GREY) 16

 ISOJET/42 (BLUE) 17

 ISOJET/42 (BLACK) 18

 ISOJET/42 (GREY) 19

 ISOJET/42 PLUS (BLUE) 20

 ISOJET/42 PLUS (GREY)..... 21

FITTINGS

 M00110/M00120/M00130 23

 M00910/M00920/M00930..... 23

 M03300..... 23

 M03400..... 24

 M03450..... 24

 M24913 24

 M01500 25

 M01700 25

 M01800 25

 M65514 26

 M57810 (DN 16: M52810)..... 26

 M66613 27

APPENDIX..... 29

“Manuli Hydraulics is focused on achieving excellence in the design, manufacture, and supply of fluid conveyance solutions, components and associated equipment for high pressure hydraulics, industrial material conveyance, refrigeration and cooling applications.”

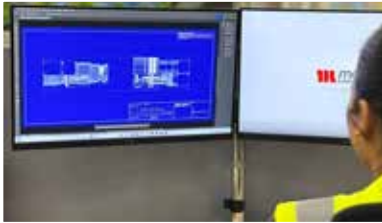

Our experienced Research & Development team take 2D drawings to 3D models to real life products.



Our world-class hoses, fittings and assembly equipment are manufactured in-house to the highest standards.



We test and validate our products to meet and exceed technical industry standards.



We provide the complete solution: hoses, fittings, crimping parameters and assembly equipment for a fully integrated system.



We supply fluid conveyance solutions directly to our customers whenever and wherever they are.

From design to manufacture, and assembly, Manuli Hydraulics’ continual commitment to this unified philosophy makes us a global leader in providing integrated solutions for fluid and material transfer connector applications including hydraulics, refrigeration & air conditioning, oil & gas, water and industrial low-pressure.

Manuli Hydraulics offer a complete range of hoses, fittings and assembly equipment which are purposely designed to work seamlessly together. This harmonized approach allows us to guarantee the quality and performance of our hose assemblies.

Every metre of hose and every single fitting is backed by industry knowledge and experience, made available to you through our dedicated team of application engineers.

From advice on component selection and configuration, our technical expertise allows us to support and work directly with our customers whenever and wherever they are based.

WATER CLEANING & BLASTING

The Water Cleaning & Blasting hose range offered by Manuli Hydraulics can be applied to both hobby and professional water cleaning machines with both hot and cold water (not suitable for vapour steam applications).

The Water Cleaning & Blasting hose range is designed for maximum robustness and ease of handling. The hose range meets safety norm IEC-2 with a safety factor (burst / working pressure) of 4:1.

INTEGRATED SOLUTIONS

Manuli hydraulics offers a dedicated selection of water cleaning & blasting fitting solutions, each designed to work seamlessly with our pressure washer and water blasting hoses.

- Given the importance of safety and performance when connected with any blasting application, the complete and dedicated fittings range has safety factor (burst / working pressure) of 2,5:1 is compliant with international specifications (AS/NZ 4233.2, RMA-USA, ISO7751, BFPA-UK, EN 1829-2).



SAFETY GUIDE

Manuli Hydraulics hose and fitting products must be assembled in strict accordance with Manuli Hydraulics instructions and limitations. Don't mix and match: always use Manuli Hydraulics original hoses and fittings. Manuli Hydraulics hose, fittings, and assembling machines are tested as an effective and reliable system. The use of different products and machines will affect and nullify any representation and/or warranty on products, their features and/or performance that may have been provided, and may cause premature hose failures, property damage, serious injury or death for which Manuli Hydraulics does not assume any responsibility and/or liability at any time whatsoever. Inside our Digital Crimp Tools, you can find the only official technical crimping parameters relating to our products and/or services. Therefore, please be sure to use the latest version of our Crimp App and Web Tool.

MANULI HYDRAULICS MAKES NO REPRESENTATIONS AND/OR WARRANTIES, EXPRESS OR IMPLIED, AND ASSUMES NO RESPONSIBILITY AND/OR LIABILITY FOR ANY LOSS OR DAMAGE, WHETHER DIRECT, INDIRECT, CONSEQUENTIAL OR INCIDENTAL WHICH MIGHT ARISE OUT FROM, OR IN CONNECTION WITH, IMPROPER AND/OR INCORRECT USE OF ITS PRODUCTS AND/OR ASSEMBLY EQUIPMENT OR FROM ANY USE OF CRIMPED HOSE ASSEMBLIES NOT PRODUCED FROM GENUINE RYCO HOSE FITTINGS, HOSE AND EQUIPMENT, AND, IN GENERAL, NOT IN ACCORDANCE WITH OUR PROCESS SPECIFICATIONS FOR EACH SPECIFIC PRODUCT AND/OR ASSEMBLY EQUIPMENT.

DISCLAIMERS

We reserve the right to modify our products and/or related services and/or discontinue the manufacture and/or supply of any of the products and/or related services, without notice. No product is warranted as being fit for a particular purpose and we do not assume any liability in connection with the use of our products other than those technically approved in writing by us, or specified in the relevant official technical specifications released by us, for specific products. This document supersedes all previous versions and previously issued documentation. The only official source of technical crimping parameters regarding our products is our Digital Crimp Tools. Printed copies are uncontrolled therefore, please be sure to use the latest versions of our [Manuli Hydraulics Crimp App](#) or visit our [Crimp Web Tool](#). For more information, please visit our dedicated '[Contact](#)' page on the [Manuli Hydraulic's website](#).



RANGE	HOSE	HOSE STRUCTURE	KEY PERFORMANCE	PAGE
WATER BLASTING	GOLDENBLAST	Wire spiral	Safe waterblast technology	9
	GOLDENBLAST/PLUS	Wire spiral		10
	GOLDENBLAST/SIX	Wire spiral		11
WATER CLEANING	ISOJET/28	High Tensile Steel Braid	Water-cleaning equipment, ideal for hobby and semiprofessional machines. Water, mineral oils, vegetable and rape seed oils, glycol and polyglycol based oils, synthetic ester based oils, oils in aqueous emulsion	12 - 14
	ISOJET/28 PLUS	High Tensile Steel Braid		15 - 16
	ISOJET/42	High Tensile Steel Braid		17 - 19
	ISOJET/42 PLUS	High Tensile Steel Braid		20 - 21

GUIDE TO SELECT MANULI HOSE BY WORKING PRESSURE

HOSE SIZE	WORKING PRESSURE (bar)									
	DN	5	6	8	10	12	16	19	25	
	DASH	-3	-4	-	-6	-8	-10	-12	-16	
GOLDENBLAST					750	750				Safety factor burst/working pressure 2,5:1
GOLDENBLAST/PLUS					1250	1100		1000	700	
GOLDENBLAST/SIX						1450		1350		
ISOJET/28			280	280	280	280				Safety factor burst/working pressure 3:1
ISOJET/28 PLUS			280	280	280	280				
ISOJET/42			420	420	420	420				
ISOJET/42 PLUS			420	420	420	420				

WATER CLEANING

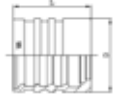
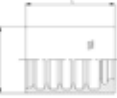
MF2000® MULTIFIT TYPE FERRULE

APPEARANCE	CODE	DESCRIPTION	PAGE
	M00120	SKIVE FERRULE FOR WIRE BRAID HOSES	23
	M00910	SKIVE FERRULE FOR WIRE BRAID AND SPIRAL HOSES	23
	M03300	NO-SKIVE FERRULE FOR WIRE BRAID HOSES	23
	M03400	NO-SKIVE FERRULE FOR WIRE BRAID HOSES	24
	M03450	NO-SKIVE FERRULE FOR WIRE BRAID HOSES	24

MF2000® MULTIFIT TYPE INSERT



APPEARANCE	CODE	DESCRIPTION	PAGE
	M24913	WASH CLEANER FEMALE	24

WATER BLASTING

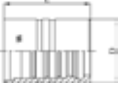
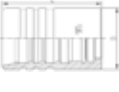
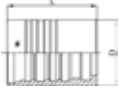
MF2000® BLASTLOCK TYPE FERRULE

APPEARANCE	CODE	DESCRIPTION	PAGE
	M01500	DOUBLE SKIVE FERRULE FOR HEAVY DUTY SPIRAL HOSES (4 PLY)	25
	M01700	DOUBLE SKIVE FERRULE FOR HEAVY DUTY SPIRAL HOSES (4 PLY)	25
	M01800	DOUBLE SKIVE FERRULE FOR EXTRA DUTY SPIRAL HOSES (6 PLY)	25

MF2000® BLASTLOCK TYPE INSERT

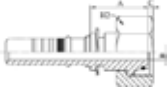
APPEARANCE	CODE	DESCRIPTION	PAGE
	M65514	BSP FEMALE 50° CONE - BS5200/ISO 8434-6	26
	M57810	NPTF MALE 60° CONE SEAT - SAE J516/J514	26
	M66613	METRIC O-RING FEMALE 24° CONE HEAVY DUTY - DIN 20066/ISO 12151-2 (SLIP-ON NUT)	27

HOSES

 **manuli**[®]
HYDRAULICS



GOLDENBLAST

SAFE WATERBLAST TECHNOLOGY



PART REF.	HOSE			R.O.D		O.D		MAX. W.P		BURST		MIN. BEND		WEIGHT		FITTINGS	
	DN	dash	inch	mm	inch	mm	inch	bar	psi	bar	psi	mm	inch	g/m	lb/ft	Std 1	Std 2
H10072010	10	-6	3/8"	17.6	0.69	20.2	0.80	750	10,870	1,875	27,190	180	7.09	756	0.51	BL+M01700-06	
H10072A12	12	-8	1/2"	20.4	0.80	23.0	0.91	750	10,870	1,875	27,190	220	8.66	905	0.61	BL+M01700-08	

KEY FEATURES

- Basic hose line for scale removing applications
- Compactness, lightness and flexibility
- Safety factor 2,5:1 (accepted world standard as specified by RMA-USA, BFPA-UK, DIN-Germany, ISO 7751)
- High abrasion resistant cover

APPLICATIONS & FLUIDS

- Waterblasting, scale removing applications using extreme high working pressures:
- Building and industrial sectors (roadworks, removal of concrete from reinforced concrete structures safeguarding metal components);
- Scale removal ships hulls in shipyard;
- Dust elimination
- Water, water soap, emulsions

CONTINUOUS SERVICE TEMPERATURE RANGE

-10 °C, 15 °F

70 °C, 158 °F

TUBE

Water resistant synthetic rubber

REINFORCEMENT

Four high tensile steel spirals

COVER

Synthetic rubber with high temperature, ozone and abrasion resistance

APPLICABLE SPECS

Manuli® Design, Australian Std. AS/NZS 4233.2

TYPE APPROVALS

CU-TR; MSHA

GOLDENBLAST/PLUS

SAFE WATERBLAST TECHNOLOGY



PART REF.	HOSE			R.O.D		O.D		MAX. W.P		BURST		MIN. BEND		WEIGHT		FITTINGS	
	DN	dash	inch	mm	inch	mm	inch	bar	psi	bar	psi	mm	inch	g/m	lb/ft	Std 1	Std 2
H10066010	10	-6	3/8"	17.4	0.69	20.0	0.79	1,250	18,120	3,125	45,320	230	9.06	800	0.54	BL+M01700-06	
H10066A12	12	-8	1/2"	21.5	0.85	24.1	0.95	1,100	15,950	2,750	39,880	230	9.06	1,110	0.75	BL+M01700-08	
H10066019	19	-12	3/4"	29.0	1.14	32.0	1.26	1,000	14,500	2,500	36,250	250	9.84	1,730	1.16	BL+M01700-12	
H10066025	25	-16	1"	35.1	1.38	38.1	1.50	700	10,150	1,750	25,380	250	9.84	2,040	1.37	BL+M01500-16	

KEY FEATURES

- Hose line for waterblasting with pressures up to 1250 bar
- Compactness, lightness and flexibility
- Safety factor 2,5:1 (accepted world standard as specified by RMA-USA, BFPA-UK, DIN-Germany, ISO 7751)
- High abrasion resistance cover

APPLICATIONS & FLUIDS

- Waterblasting, scale removing applications using extreme high working pressures:
- Building and industrial sectors (roadworks, removal of concrete from reinforced concrete structures safeguarding metal components);
- Scale removal ships hulls in shipyard;
- Dust elimination
- Water, water soap, emulsions

CONTINUOUS SERVICE TEMPERATURE RANGE

-10 °C, 15 °F
70 °C, 158 °F

TUBE

Water resistant synthetic rubber

REINFORCEMENT

Four high tensile steel spirals

COVER

Synthetic rubber with very high temperature, ozone and abrasion resistance

APPLICABLE SPECS

Manuli® Design, Australian Std. AS/NZS 4233.2

TYPE APPROVALS

CU-TR; MSHA

HOSES 10

GOLDENBLAST/SIX

SAFE WATERBLAST TECHNOLOGY



PART REF.	HOSE			R.O.D		O.D		MAX. W.P		BURST		MIN. BEND		WEIGHT		FITTINGS	
	DN	dash	inch	mm	inch	mm	inch	bar	psi	bar	psi	mm	inch	g/m	lb/ft	Std 1	Std 2
H10067012	12	-8	1/2"	25.9	1.02	28.9	1.14	1,450	21,030	3,625	52,570	250	9.84	1,880	1.26	BL+M01800-08	
H10067019	19	-12	3/4"	32.4	1.28	35.4	1.39	1,350	19,580	3,375	48,950	280	11.02	2,630	1.77	BL+M01800-12	

KEY FEATURES

- Six wire spiral hose dedicated to severe applications with pressures up to 1450 bar
- Compactness, lightness and flexibility
- Safety factor 2,5:1 (accepted world standard as specified by RMA-USA, BFPA-UK, DIN-Germany, ISO 7751)
- High abrasion resistance cover

APPLICATIONS & FLUIDS

- Waterblasting, scale removing applications using extreme high working pressures:
- Building and industrial sectors (roadworks, removal of concrete from reinforced concrete structures safeguarding metal components);
- Scale removal ships hulls in shipyard;
- Dust elimination
- Water, water soap, emulsions

CONTINUOUS SERVICE TEMPERATURE RANGE

-10 °C, 15 °F

70 °C, 158 °F

TUBE

Water resistant synthetic rubber

REINFORCEMENT

Six high tensile steel spirals

COVER

Synthetic rubber with very high temperature, ozone and abrasion resistance

APPLICABLE SPECS

Manuli® Design, Australian Std. AS/NZS 4233.2

TYPE APPROVALS

CU-TR; MSHA

ISOJET/28 (BLUE)

PRESSURE WASH - BLUE VERSION



PART REF.	HOSE			R.O.D		O.D		MAX. W.P		BURST		MIN. BEND		WEIGHT		FITTINGS	
	DN	dash	inch	mm	inch	mm	inch	bar	psi	bar	psi	mm	inch	g/m	lb/ft	Std 1	Std 2
H01190006*	6	-4	1/4"	9.9	0.38	11.7	0.46	280	4,060	840	12,183	50	1.96	158	0.11	MF + M03300-04	
H01190008*	8	-5	5/16"	11.4	0.44	13.1	0.51	280	4,060	840	12,183	55	2.16	181	0.12	MF + M03300-05	
H01190010*	10	-6	3/8"	13.3	0.52	15.3	0.6	280	4,060	840	12,183	65	2.55	235	0.16	MF + M03300-06	
H01190012*	12	-8	1/2"	16.7	0.65	18.5	0.72	280	4,060	840	12,183	90	3.54	330	0.22	MF + M03300-08	

KEY FEATURES

- Wrapped surface
- Indelible branding
- Compact structure: easy handling, reduced bend radius
- Good abrasion resistance
- Safety Factor 3:1

APPLICATIONS & FLUIDS

- Water-cleaning equipment, ideal for hobby and semi-professional machines
- Water, mineral oils, vegetable and rape seed oils, glycol and polyglycol based oils, synthetic ester based oils, oils in aqueous emulsion

CONTINUOUS SERVICE TEMPERATURE RANGE

-10 °C, 15 °F

135 °C, 275 °F

TUBE

Water resistant synthetic rubber

REINFORCEMENT

One high tensile steel braid

COVER

Weather resistant synthetic rubber

APPLICABLE SPECS

Manuli® Design

HOSES 12

ISOJET/28 (BLACK)

PRESSURE WASH - BLACK VERSION



PART REF.	HOSE			R.O.D		O.D		MAX. W.P		BURST		MIN. BEND		WEIGHT		FITTINGS	
	DN	dash	inch	mm	inch	mm	inch	bar	psi	bar	psi	mm	inch	g/m	lb/ft	Std 1	Std 2
H01189006*	6	-4	1/4"	9.9	0.38	11.7	0.46	280	4,060	840	12,183	50	1.96	154	0.10	MF + M03300-04	
H01189008*	8	-5	5/16"	11.4	0.44	13.1	0.51	280	4,060	840	12,183	55	2.16	177	0.12	MF + M03300-05	
H01189010*	10	-6	3/8"	13.3	0.52	15.3	0.6	280	4,060	840	12,183	65	2.55	229	0.15	MF + M03300-06	
H01189012*	12	-8	1/2"	16.7	0.65	18.5	0.72	280	4,060	840	12,183	90	3.54	323	0.22	MF + M03300-08	

KEY FEATURES

- Wrapped surface
- Indelible branding
- Compact structure: easy handling, reduced bend radius
- Good abrasion resistance
- Safety Factor 3:1

APPLICATIONS & FLUIDS

- Water-cleaning equipment, ideal for hobby and semi-professional machines
- Water, mineral oils, vegetable and rape seed oils, glycol and polyglycol based oils, synthetic ester based oils, oils in aqueous emulsion

CONTINUOUS SERVICE TEMPERATURE RANGE

-10 °C, 15 °F

135 °C, 275 °F

TUBE

Water resistant synthetic rubber

REINFORCEMENT

One high tensile steel braid

COVER

Weather resistant synthetic rubber

APPLICABLE SPECS

Manuli® Design

ISOJET/28 (GREY)

PRESSURE WASH - GREY VERSION



PART REF.	HOSE			R.O.D		O.D		MAX. W.P		BURST		MIN. BEND		WEIGHT		FITTINGS	
	DN	dash	inch	mm	inch	mm	inch	bar	psi	bar	psi	mm	inch	g/m	lb/ft	Std 1	Std 2
H01191006*	6	-4	1/4"	9.9	0.38	11.7	0.46	280	4,060	840	12,183	50	1.96	164	0.11	MF + M03300-04	
H01191010*	10	-6	3/8"	13.3	0.52	15.3	0.6	280	4,060	840	12,183	65	2.55	244	0.16	MF + M03300-06	

KEY FEATURES

- Animal fat resistant
- Wrapped surface
- Indelible branding
- Compact structure: easy handling, reduced bend radius
- Safety Factor 3:1

APPLICATIONS & FLUIDS

- Water-cleaning equipment, ideal for hobby and semi-professional machines
- Water, mineral oils, vegetable and rape seed oils, glycol and polyglycol based oils, synthetic ester based oils, oils in aqueous emulsion

CONTINUOUS SERVICE TEMPERATURE RANGE

-10 °C, 15 °F

135 °C, 275 °F

TUBE

Water resistant synthetic rubber

REINFORCEMENT

One high tensile steel braid

COVER

Weather resistant synthetic rubber, animal fat resistant

APPLICABLE SPECS

Manuli® Design

HOSES 14

ISOJET/28 PLUS (BLUE)

PRESSURE WASH - BLUE VERSION



PART REF.	HOSE			R.O.D		O.D		MAX. W.P		BURST		MIN. BEND		WEIGHT		FITTINGS	
	DN	dash	inch	mm	inch	mm	inch	bar	psi	bar	psi	mm	inch	g/m	lb/ft	Std 1	Std 2
H01198006*	6	-4	1/4"	9.9	0.38	12.7	0.5	280	4,060	840	12,183	50	1.96	184	0.12	MF + M03300-04	
H01198010*	10	-6	3/8"	13.3	0.52	16.1	0.63	280	4,060	840	12,183	65	2.55	262	0.18	MF + M03300-06	

KEY FEATURES

- Wrapped surface
- Indelible branding
- Compact structure: easy handling, reduced bend radius
- Good abrasion resistance
- Safety Factor 3:1

APPLICATIONS & FLUIDS

- Water-cleaning equipment, ideal for hobby and semi-professional machines
- Water, mineral oils, vegetable and rape seed oils, glycol and polyglycol based oils, synthetic ester based oils, oils in aqueous emulsion

CONTINUOUS SERVICE TEMPERATURE RANGE

-10 °C, 15 °F
135 °C, 275 °F

TUBE

Water resistant synthetic rubber

REINFORCEMENT

One high tensile steel braid

COVER

Weather resistant synthetic rubber

APPLICABLE SPECS

Manuli® Design

ISOJET/28 PLUS (GREY)

PRESSURE WASH - GREY VERSION



PART REF.	HOSE			R.O.D		O.D		MAX. W.P		BURST		MIN. BEND		WEIGHT		FITTINGS	
	DN	dash	inch	mm	inch	mm	inch	bar	psi	bar	psi	mm	inch	g/m	lb/ft	Std 1	Std 2
H01196006*	6	-4	1/4"	9.9	0.38	12.7	0.5	280	4,060	840	12,183	50	1.96	190	0.13	MF + M03300-04	
H01196010*	10	-6	3/8"	13.3	0.52	16.1	0.63	280	4,060	840	12,183	65	2.55	271	0.18	MF + M03300-06	

KEY FEATURES

- Wrapped surface
- Indelible branding
- Compact structure: easy handling, reduced bend radius
- Good abrasion resistance
- Safety Factor 3:1

APPLICATIONS & FLUIDS

- Water-cleaning equipment, ideal for hobby and semi-professional machines
- Water, mineral oils, vegetable and rape seed oils, glycol and polyglycol based oils, synthetic ester based oils, oils in aqueous emulsion

CONTINUOUS SERVICE TEMPERATURE RANGE

-10 °C, 15 °F

135 °C, 275 °F

TUBE

Water resistant synthetic rubber

REINFORCEMENT

One high tensile steel braid

COVER

Weather resistant synthetic rubber

APPLICABLE SPECS

Manuli® Design

HOSES 16

ISOJET/42 (BLUE)

PRESSURE WASH - BLUE VERSION



PART REF.	HOSE			R.O.D		O.D		MAX. W.P		BURST		MIN. BEND		WEIGHT		FITTINGS	
	DN	dash	inch	mm	inch	mm	inch	bar	psi	bar	psi	mm	inch	g/m	lb/ft	Std 1	Std 2
H01193006*	6	-4	1/4"	11.2	0.44	13.2	0.51	420	6,090	1,260	18,275	50	1.96	258	0.17	MF + M03400-04	
H01193008*	8	-5	5/16"	13	0.51	15	0.59	420	6,090	1,260	18,275	55	2.16	316	0.21	MF + M03400-05	
H01193010*	10	-6	3/8"	14.6	0.57	16.8	0.66	420	6,090	1,260	18,275	65	2.55	372	0.25	MF + M03400-06	
H01193012*	12	-8	1/2"	18.6	0.73	20.6	0.81	420	6,090	1,260	18,275	90	3.54	521	0.35	MF + M03450-08	

KEY FEATURES

- Wrapped surface
- Indelible branding
- Compact structure: easy handling, reduced bend radius
- Good abrasion resistance
- Safety Factor 3:1

APPLICATIONS & FLUIDS

- Water-cleaning equipment, ideal for hobby and semi-professional machines
- Water, mineral oils, vegetable and rape seed oils, glycol and polyglycol based oils, synthetic ester based oils, oils in aqueous emulsion

CONTINUOUS SERVICE TEMPERATURE RANGE

-10 °C, 15 °F
135 °C, 275 °F

TUBE

Water resistant synthetic rubber

REINFORCEMENT

Two high tensile steel braids

COVER

Weather resistant synthetic rubber

APPLICABLE SPECS

Manuli® Design

ISOJET/42 (BLACK)

PRESSURE WASH - BLACK VERSION



PART REF.	HOSE			R.O.D		O.D		MAX. W.P		BURST		MIN. BEND		WEIGHT		FITTINGS	
	DN	dash	inch	mm	inch	mm	inch	bar	psi	bar	psi	mm	inch	g/m	lb/ft	Std 1	Std 2
H01192006*	6	-4	1/4"	11.2	0.44	13.2	0.51	420	6,090	1,260	18,275	50	1.96	253	0.17	MF + M03400-04	
H01192008*	8	-5	5/16"	13	0.51	15	0.59	420	6,090	1,260	18,275	55	2.16	310	0.21	MF + M03400-05	
H01192010*	10	-6	3/8"	14.6	0.57	16.8	0.66	420	6,090	1,260	18,275	65	2.55	365	0.25	MF + M03400-06	
H01192012*	12	-8	1/2"	18.6	0.73	20.6	0.81	420	6,090	1,260	18,275	90	3.54	513	0.34	MF + M03450-08	

KEY FEATURES

- Wrapped surface
- Indelible branding
- Compact structure: easy handling, reduced bend radius
- Good abrasion resistance
- Safety Factor 3:1

APPLICATIONS & FLUIDS

- Water-cleaning equipment, ideal for hobby and semi-professional machines
- Water, mineral oils, vegetable and rape seed oils, glycol and polyglycol based oils, synthetic ester based oils, oils in aqueous emulsion

CONTINUOUS SERVICE TEMPERATURE RANGE

-10 °C, 15 °F

135 °C, 275 °F

TUBE

Water resistant synthetic rubber

REINFORCEMENT

Two high tensile steel braids

COVER

Weather resistant synthetic rubber

APPLICABLE SPECS

Manuli® Design

ISOJET/42 (GREY)

PRESSURE WASH - GREY VERSION



PART REF.	HOSE			R.O.D		O.D		MAX. W.P		BURST		MIN. BEND		WEIGHT		FITTINGS	
	DN	dash	inch	mm	inch	mm	inch	bar	psi	bar	psi	mm	inch	g/m	lb/ft	Std 1	Std 2
H01194010*	10	-6	3/8"	14.6	0.57	16.8	0.66	420	6,090	1,260	18,275	65	2.55	382	0.26	MF + M03400-06	
H01194012*	12	-8	1/2"	18.6	0.73	20.6	0.81	420	6,090	1,260	18,275	90	3.54	532	0.36	MF + M03450-08	

KEY FEATURES

- Animal fat resistant
- Wrapped surface
- Indelible branding
- Compact structure: easy handling, reduced bend radius
- Safety Factor 3:1

APPLICATIONS & FLUIDS

- Water-cleaning equipment, ideal for hobby and semi-professional machines
- Water, mineral oils, vegetable and rape seed oils, glycol and polyglycol based oils, synthetic ester based oils, oils in aqueous emulsion

CONTINUOUS SERVICE TEMPERATURE RANGE

-10 °C, 15 °F
135 °C, 275 °F

TUBE

Water resistant synthetic rubber

REINFORCEMENT

Two high tensile steel braids

COVER

Weather resistant synthetic rubber, animal fat resistant

APPLICABLE SPECS

Manuli® Design

ISOJET/42 PLUS (BLUE)

PRESSURE WASH - BLUE VERSION



PART REF.	HOSE			R.O.D		O.D		MAX. W.P		BURST		MIN. BEND		WEIGHT		FITTINGS	
	DN	dash	inch	mm	inch	mm	inch	bar	psi	bar	psi	mm	inch	g/m	lb/ft	Std 1	Std 2
H01195006*	6	-4	1/4"	11.2	0.44	14	0.55	420	6,090	1,260	18,275	50	1.96	281	0.19	MF + M03400-04	
H01195008*	8	-5	5/16"	13	0.51	15.8	0.62	420	6,090	1,260	18,275	55	2.16	341	0.23	MF + M03400-05	
H01195010*	10	-6	3/8"	14.6	0.57	17.4	0.68	420	6,090	1,260	18,275	65	2.55	394	0.26	MF + M03400-06	
H01195012*	12	-8	1/2"	18.6	0.73	20.6	0.81	420	6,090	1,260	18,275	90	3.54	521	0.35	MF + M03450-08	

KEY FEATURES

- Wrapped surface
- Indelible branding
- Compact and robust structure: easy handling, reduced bend radius
- Good abrasion resistance
- Safety Factor 3:1

APPLICATIONS & FLUIDS

- Water-cleaning equipment, dedicated to professional machines and applications
- Water, mineral oils, vegetable and rape seed oils, glycol and polyglycol based oils, synthetic ester based oils, oils in aqueous emulsion

CONTINUOUS SERVICE TEMPERATURE RANGE

-10 °C, 15 °F

135 °C, 275 °F

TUBE

Water resistant synthetic rubber

REINFORCEMENT

Two high tensile steel braids

COVER

Weather resistant synthetic rubber

APPLICABLE SPECS

Manuli® Design

HOSES 20

ISOJET/42 PLUS (GREY)

PRESSURE WASH - GREY VERSION



PART REF.	HOSE			R.O.D		O.D		MAX. W.P		BURST		MIN. BEND		WEIGHT		FITTINGS	
	DN	dash	inch	mm	inch	mm	inch	bar	psi	bar	psi	mm	inch	g/m	lb/ft	Std 1	Std 2
H01197010*	10	-6	3/8"	14.6	0.57	17.4	0.68	420	6,090	1,260	18,275	65	2.55	402	0.27	MF + M03400-06	
H01197012*	12	-8	1/2"	18.6	0.73	20.6	0.81	420	6,090	1,260	18,275	90	3.54	529	0.36	MF + M03450-08	

KEY FEATURES

- Wrapped surface
- Indelible branding
- Compact and robust structure: easy handling, reduced bend radius
- Good abrasion resistance
- Safety Factor 3:1

APPLICATIONS & FLUIDS

- Water-cleaning equipment, dedicated to professional machines and applications
- Water, mineral oils, vegetable and rape seed oils, glycol and polyglycol based oils, synthetic ester based oils, oils in aqueous emulsion

CONTINUOUS SERVICE TEMPERATURE RANGE

-10 °C, 15 °F
135 °C, 275 °F

TUBE

Water resistant synthetic rubber

REINFORCEMENT

Two high tensile steel braids

COVER

Weather resistant synthetic rubber

APPLICABLE SPECS

Manuli® Design

FITTINGS

 **manuli**[®]
HYDRAULICS



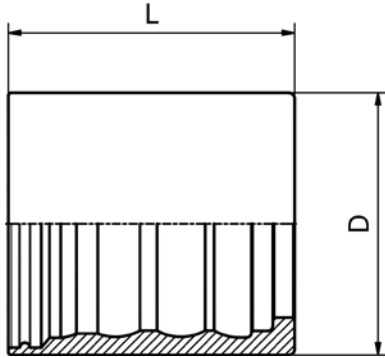

FERRULE

M00110/M00120/M00130

SKIVE FERRULE
FOR WIRE BRAID HOSES

PART. REF.	HOSE BORE			DIMENSIONS mm							
	DN	Dash	inch			D	L				
M00120-04	6	- 4	1/4"			19.5	28.0				
M00120-05	8	- 5	5/16"			20.0	28.6				

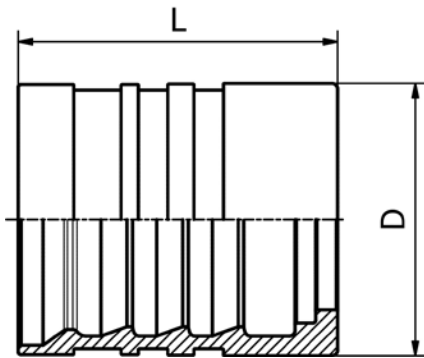

FERRULE

M00910/M00920/M00930

SKIVE FERRULE
FOR WIRE BRAID
AND SPIRAL HOSES

PART. REF.	HOSE BORE			DIMENSIONS mm							
	DN	Dash	inch			D	L				
M00910-06	10	- 6	3/8"			26.0	33.0				
M00910-08	12	- 8	1/2"			30.0	34.0				

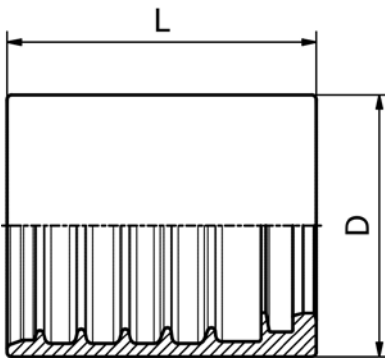

FERRULE

M03300

NO-SKIVE FERRULE
FOR WIRE BRAID HOSES

PART. REF.	HOSE BORE			DIMENSIONS mm							
	DN	Dash	inch			D	L				
M03300-04	6	- 4	1/4"			20.5	27.5				
M03300-05	8	- 5	5/16"			22.8	28.5				
M03300-06	10	- 6	3/8"			25.0	30.0				
M03300-08	12	- 8	1/2"			28.0	33.0				

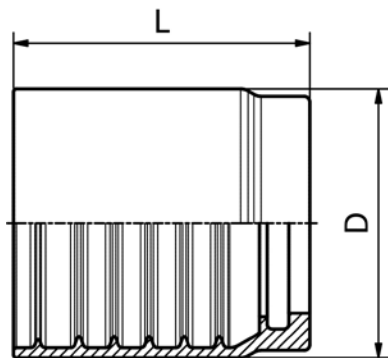

FERRULE

M03400

**NO-SKIVE FERRULE
FOR WIRE BRAID HOSES**

PART. REF.	HOSE BORE					DIMENSIONS mm						
	DN	Dash	inch			D	L					
M03400-04	6	- 4	1/4"			23.0	30.1					
M03400-05	8	- 5	5/16"			24.0	30.0					
M03400-06	10	- 6	3/8"			26.0	31.1					
M03400-10	16	- 10	5/8"			33.0	37.0					
M03400-12	19	- 12	3/4"			37.0	42.0					

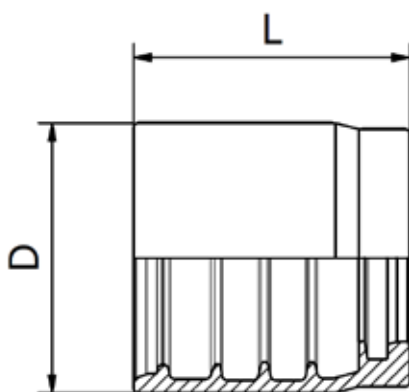

FERRULE

M03450

**NO-SKIVE FERRULE
FOR WIRE BRAID HOSES**

PART. REF.	HOSE BORE					DIMENSIONS mm						
	DN	Dash	inch			D	L					
M03450-08	12	- 8	1/2"			30.3	31.0					

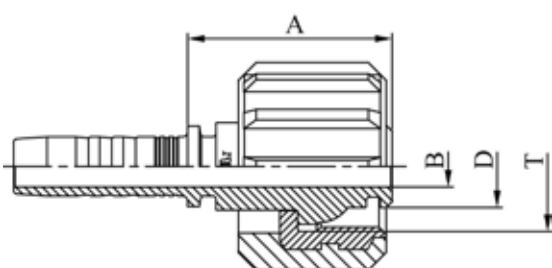

CONNECTIONS - CLEANING

M24913

WASH CLEANER FEMALE

PART. REF.	HOSE BORE			Thread		DIMENSIONS mm						
	DN	Dash	inch	T		B	A	D				
M24913-04-22	6	- 4	1/4"	M 22X1,5		4.0	34.0	13.9				
M24913-05-22	8	- 5	5/16"	M 22X1,5		5.5	34.0	13.9				
M24913-06-22	10	- 6	3/8"	M 22X1,5		7.0	34.5	13.9				

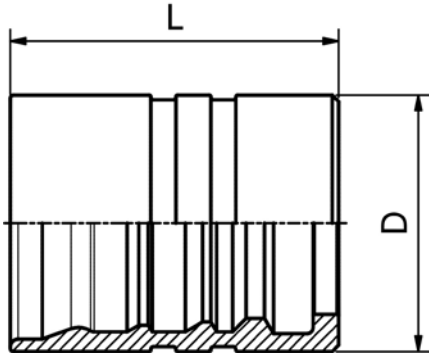

FERRULE

M01500

DOUBLE SKIVE FERRULE FOR HEAVY DUTY SPIRAL HOSES (4 PLY)

PART. REF.	HOSE BORE			DIMENSIONS mm							
	DN	Dash	inch			D	L				
M01500-16	25	-16	1"			48.0	64.5				

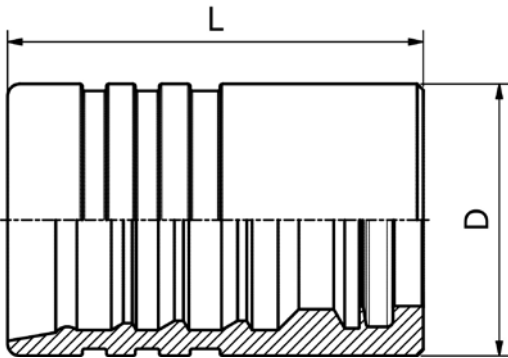

FERRULE - BLASTING

M01700

DOUBLE SKIVE FERRULE FOR EXTRA DUTY SPIRAL HOSES (4 PLY)

PART. REF.	HOSE BORE			DIMENSIONS mm							
	DN	Dash	inch			D	L				
M01700-06	10	-6	3/8"			27.9	57.5				
M01700-08	12	-8	1/2"			34.0	65.0				
M01700-12	19	-12	3/4"			45.1	69.0				

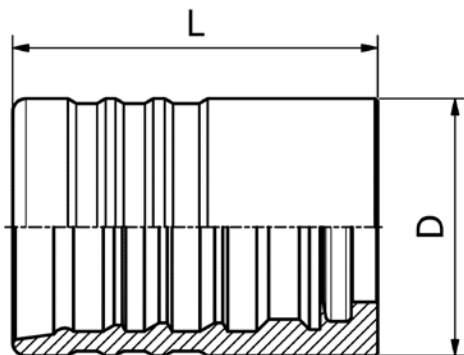

FERRULE - BLASTING

M01800

DOUBLE SKIVE FERRULE FOR EXTRA DUTY SPIRAL HOSES (6 PLY)

PART. REF.	HOSE BORE			DIMENSIONS mm							
	DN	Dash	inch			D	L				
M01800-08	12	-8	1/2"			38.3	64.4				
M01800-12	19	-12	3/4"			48.6	69.0				

25 FITTINGS

CONNECTIONS - BLASTING

M65514

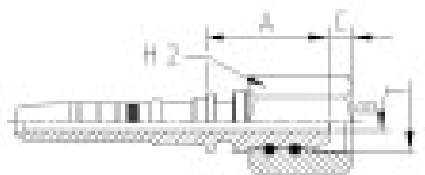

**BSP FEMALE 60° CONE
(BS5200 - ISO 8434-6)**

PART. REF.	HOSE BORE			THREAD	DIMENSIONS mm						
	DN	Dash	inch	T	B	A	C	H2			
M65514-06-06	10	-6	3/8"	3/8" - 19	4.8	34.5	6.0	24.0			
M65514-08-08	12	-8	1/2"	1/2" - 14	9.0	37.0	6.5	30.0			
M65514-12-12	19	-12	3/4"	3/4" - 14	12.0	43.0	8.7	36.0			

The BLASTLOCK fittings have to be used with the GOLDENBLAST hoses only, that are suggested for waterblasting applications. For hydraulic applications please refer to the dedicated fittings (ILP).

"B" dimension does not comply with: BS5200 and ISO8434-6 spec.

CONNECTIONS - BLASTING

M57810 (DN 16: M52810)

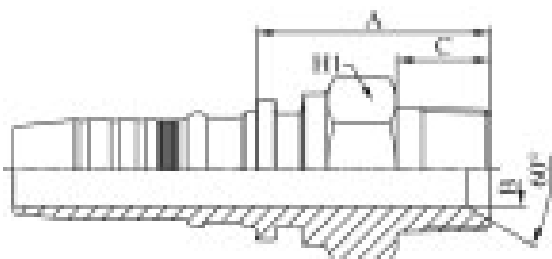

**NPTF MALE 60° CONE SEAT
- SAE J516/J514**

PART. REF.	HOSE BORE			THREAD	DIMENSIONS mm						
	DN	Dash	inch	T	B	A	C	H1			
M57810-06-06	10	-6	3/8"	3/8" - 18	8.5	38.0	15.5	22.0			
M57810-08-08	12	-8	1/2"	1/2" - 14	10.0	44.5	21.0	27.0			
M57810-12-12	19	-12	3/4"	3/4" - 14	15.0	49.5	21.0	32.0			
M57810-16-16	25	-16	1"	1" - 11	19.5	55.0	24.2	41.0			

The BLASTLOCK fittings have to be used with the GOLDENBLAST hoses only, that are suggested for waterblasting applications. For hydraulic applications please refer to the dedicated fittings (ILP).

CONNECTIONS - BLASTING

M66613

**METRIC O-RING FEMALE 24° CONE HEAVY DUTY
- DIN 20066/ISO
12151-2 (SLIP-ON NUT)**

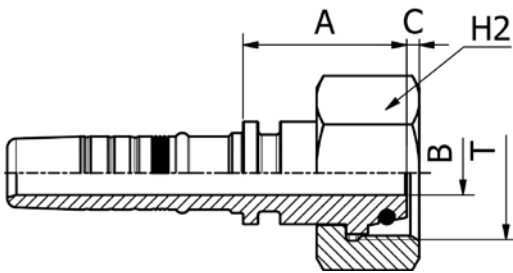

PART. REF.	HOSE BORE			THREAD	PIPE	DIMENSIONS mm						
	DN	Dash	inch	T	mm	B	A	C	H2			
M66613-06-22	10	-6	3/8"	M 22 X 1.5	14	4.8	32.0	3.5	27.0			
M66613-06-24	10	-6	3/8"	M 24 X 1.5	16	6.3	34.0	4.0	32.0			
M66613-08-24	12	-8	1/2"	M 24 X 1.5	16	9.0	35.5	4.0	32.0			
M66613-12-36	19	-12	3/4"	M 36 X 2	25	12.0	44.5	3.4	46.0			
M66613-16-42	25	-16	1"	M 42 X 2	30	19.5	43.5	5.3	50.0			

The BLASTLOCK fittings have to be used with the GOLDENBLAST hoses only, that are suggested for waterblasting applications. For hydraulic applications please refer to the dedicated fittings (ILP).





The following assembling instructions are strongly recommended for heavy-duty applications

BLASTLOCK FITTINGS ASSEMBLY INSTRUCTIONS

The crimping operation to apply BLASTLOCK fittings must be carried out with proper high performance crimping/assembling machines, with a crimping force higher than 2,800-3,000 kN, and approved by Manuli Hydraulics. This is in order to guarantee the optimum coupling assembly deformations and correct hose gripping.

It is recommended that the detailed assembling instructions are followed. These are supplied by Manuli Hydraulics to customers, assemblers and operators using the integrated package, GOLDENBLAST hose & BLASTLOCK fittings.

Each assembly must be pressure tested at the pressure level required by the reference specifications (e.g. EN 1829-2 requirement is 1.5 times the WP for minimum 30 seconds) and taking into consideration all safety implications.

Specialised personnel are recommended for the assembling operation of BLASTLOCK fittings.

PART REF.	THREAD SIZE	OR SUPPLIED (NBR 90 Sha)	TIGHTENING TORQUE (Nm)
M66613-6-22	M 22 x 1.5	10 x 2	70
M66613-08-24	M 24 x 1.5	12 x 2	100
M66613-12-36	M 36 x 2	20.3 x 2.4	190
M66613-16-42	M 42 x 2	25.3 x 2.4	220

MANULI GOLDENBLAST RECOMMENDATIONS

Please see the following recommendations for the safe and correct use of the Manuli Goldenblast product line:

- Don't mix and match: MRI highly recommends the use of its integrated waterblasting package. The use of alternative hose or fittings can result in poor quality and reliability of the assembly.
- In line with international regulations, all waterblasting assemblies should be tested to 150% of the indicated maximum static working pressure before using.
- If waterblasting assemblies are used at a pressure exceeding the maximum working pressure indicated, the assemblies structure can cause an over-stressed situation. For the same reason pulsating pressure situations also need to be avoided.
- Relief valves should be used to preserve waterblasting equipment and hose assemblies.
- When safety devices are applied to prevent fitting blow-off, hose elongation and contraction needs to be taken in consideration. Under pressure, the hose length can vary between -4% to +2%.
- Waterblasting assemblies should never be used in "hang down" positions. These conditions can cause hose reinforcement restriction to contraction/elongation and over-stress fittings when supporting the weight of the hanging hose.
- Strictly avoid applying any external force on the hose assembly, such as axial tension, twisting, kinking or crushing.
- Temperature influences the resistance to leakage. Working temperature should be maintained below 70°C.
- Hose assemblies need to be replaced in case of damage, such as:
 - hose cover abrasion, cuts, chemical attack, corrosion
 - reinforcement crushing or twisting
- High pressure water must always be considered as extremely dangerous. Anyone handling waterblasting equipment should wear proper protective clothing, boots and eye protection.

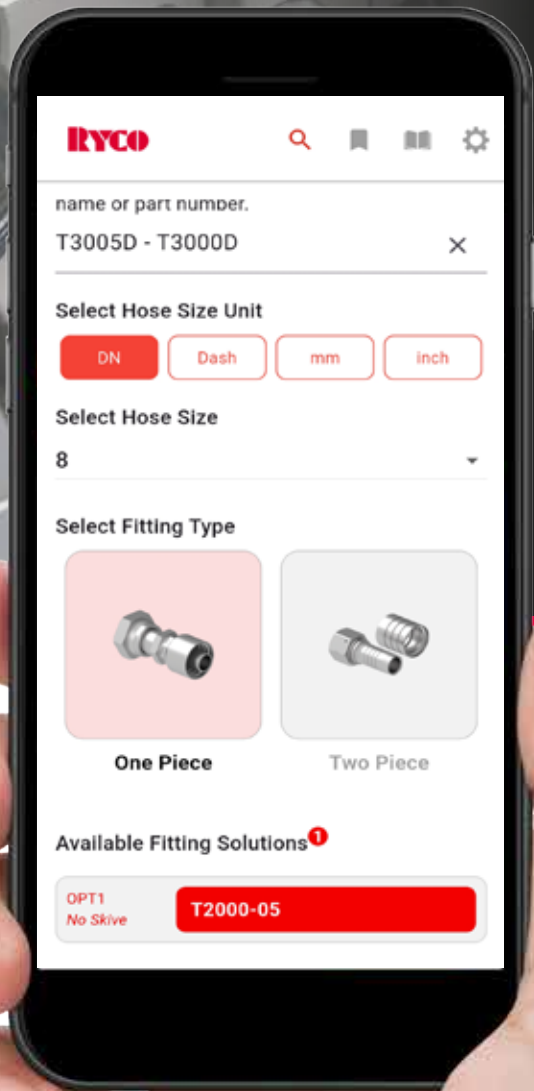

manuli[®] HYDRAULICS **CRIMP**

YOUR SOURCE FOR THE MOST UP TO DATE CRIMP PARAMETERS

Stay up to date using Manuli's Digital Crimp Tools, available as an App and a Web version, our Crimp Tools are your go-to resource for accurate, efficient, and safe hydraulic hose crimping. Designed with professionals in mind, this innovative tool grants instant access to the latest crimp specifications, ensuring precision, and reliability in every assembly.

Whether in the workshop or on the go, Manuli Digital Crimp Tools provide real-time access to an extensive database of hose and fitting specifications, helping to reduce downtime and boost productivity.

Key Features of Ryco's Digital Crimp Tools:

Print Feature: This feature supports printing crimping parameters as reference charts for both single or multiple hose sizes within a selected hose family, supporting workshop and warehouse use.

Saved Items: Frequently used hose and fitting combinations can be saved within the app, allowing quick access to commonly used crimping parameters during routine hose assembly tasks.

Technical Centre: The Digital Crimp Tools are supported by a dedicated section on our website called the Technical Centre. This integrated resource provides expert insights, practical tips, and industry knowledge, with access to in depth guides and best practice information.

Current Crimping Parameters: To ensure accuracy on their crimping parameters, customers should regularly access the Manuli Digital Crimp Tools to check for updates. It is also recommended that printed charts should be reprinted regularly to ensure crimping information remains up to date.

Download the Manuli Crimp App Now



www.ryco-hydraulics.com



SCAN HERE FOR
CONTACT INFORMATION

manuli[®]
HYDRAULICS

www.manuli-hydraulics.com