

LARGE BORE SWIVEL ADAPTORS

Manuli Hydraulics offers a range of large bore thrust wire swivel adaptors to cover those situations where traditional crimp technology cannot offer a swivel solution.

These latest innovations from Manuli Hydraulics include both the SA and SH series of staple lock connectors.

Provided by a single thrust wire in the SA series, and by a double thrust wire in the high-performance SH series, the swivel design provides additional benefits and flexibility to large bore adaptors.



SA Series Single Thrust Wire Swivel



SH Series Double Thrust Wire Swivel

KEY BENEFITS

- Compact and versatile design
- Greater flexibility for efficient system design over conventional fixed solutions
- Simplifies installation of hydraulic equipment and systems
- Enables female staple hole orientation
- Seloc pin fully retains thrust wire
- Design suitable for both low- and high-pressure applications
- Matches performance criteria of existing fixed designs
- Technology can be applied to all DN38 (1½") and DN51 (2") fixed female designs

Stainless Steel Seloc Retaining Pin

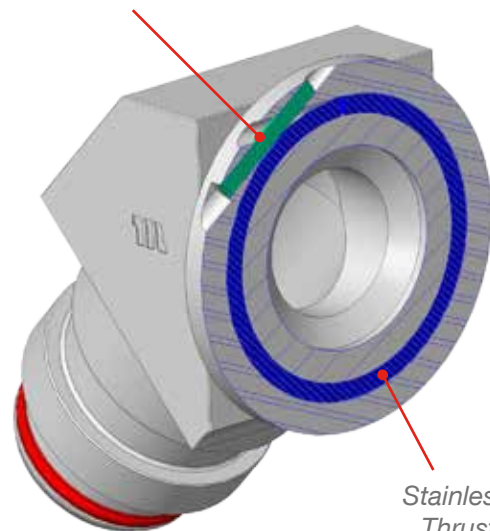

Stainless Steel Thrust Wire