



ASSEMBLY MACHINES

Manuli assembling machines are part of our integrated product range and are designed according to high quality standards and optimised through Manuli's extensive experience in the hydraulic market.

Manuli assembling machines are recommended for a high-performance, safe hose assembling procedure.

All Manuli assembling machines are tested and approved in both laboratory and field validation exercises.

The following index offers a guideline to aid selection of the proper machine with reference to the applications and performance requested.

Special machines (not included in this catalogue) are available upon request, as well as original spare parts.

Manuli hose and fittings products must be assembled in strict accordance with Manuli instructions and limitations.

Don't mix and match: always use Manuli original couplings and hoses.

Manuli hose, couplings and assembling machines are tested as an effective and reliable system. The use of different products and machines may cause premature hose failures, property damage, serious injury or death.

MANULI MAKES NO WARRANTIES, EXPRESS OR IMPLIED, AND ASSUMES NO RESPONSIBILITY OR LIABILITY FOR ANY LOSS OR DAMAGE, WHETHER DIRECT, INDIRECT, CONSEQUENTIAL OR INCIDENTAL WHICH MIGHT ARISE OUT OF CRIMPED HOSE ASSEMBLIES NOT PRODUCED FROM GENUINE MANULI HOSE FITTINGS, HOSE AND EQUIPMENT, IN CONFORMANCE WITH MANULI PROCESS SPECIFICATIONS FOR EACH SPECIFIC HOSE ASSEMBLY.

The latest edition of the Manuli crimping booklet is the only official guide to selecting proper hose and fittings combinations and for determining crimping compatibility and parameters.

Manuli is always on the lookout for ways to improve both the efficiency and the quality of new and existing production operations.

As a market leader in assembly machines, we wanted to offer new crimping machines to improve the operator's comfort, giving more flexibility when assembling hoses. This led to the creation of the new EVO crimping machines.

These machines combine the robustness required for harsh environments with the reliability needed for busy workshops. Their compact and ergonomic design, along with the ease of set up and maintenance, make them suitable for a variety of applications.

This extensive range is highly adaptable, with various options available allowing users to customise their machine according to their specific needs.

- Extensive range for both industrial and hydraulic hoses



- 137, 240, 350 and 420 tonnes variants
- From 3/16 up to 4" hose diameter
- 4 kW or 5,5 kW motor for 3Ph

- Bluetooth connection



- SC panel - Smart Control panel. Daily counter. Semi-automatic opening



- SCE panel - electronic micrometer with the ability to save up to 25 configuration
- Caliper connected and numerical display of the crimping range on SCE

- Robust
- Ease of maintenance (foam pads and dust collector)
- Compatibility with all tensions (different frequencies)



- Compact and ergonomic design
- Easy set up
- Various options available to suit our customers' needs and workshops



	MODEL	MACHINE TYPE	APPLICATION SECTOR	MACHINE PERFORMANCE	PAGE
CUTTING	M 22 CUT / MV 22 CUT	Benchtop	Aftermarket service	Medium size capacity	
	M 30 CUT E	Benchtop cutting machine, optional skiving	Aftermarket service	Wide hose range capacity	
	M 30 CUT & SKIVE	Benchtop: integrated cutting & skiving	Aftermarket service	Wide hose range capacity	
	M 30 CUT L	Stand type cutting machine	Aftermarket service (smoke absorption integrated)	Wide hose range capacity	
	M 55 CUT	Stand type cutting machine	Aftermarket service and small-medium OEM workshop	Whole hose range capacity	
	M 75 CUT	Stand type cutting machine	Production unit	Whole hose range capacity	
	M 90 CUT	Stand type cutting machine	Production unit	Whole hose range capacity	
SKIVING	MH SKY	Manual, portable skiving tool	Aftermarket service	Wide hose range capacity	
	M 50 SKY	Benchtop, skiving	Aftermarket service	Wide hose range capacity	
	M 205 SKY	Stand type skive machine	Production unit	Whole hose range capacity	
INSERT PUSHING	M 1500 INS	Benchtop coupling inserter	Production unit	Whole hose range capacity	
	M 4000 INS	Benchtop coupling inserter	Production unit	Whole hose range capacity	
MARKING	M 50 MARK	Benchtop, ferrules marking	Aftermarket service	Wide hose range capacity	
CRIMPING	MHP 80	Hand pump, portable	On site repair	Manual machine for small sizes	
	MHP 110	Hand pump, portable	On site repair	Manual machine for small sizes	
	MHP 137	Hand pump, portable	On site repair	Manual machine for small/medium sizes	
	MRB 137 EVO R	Vertical Benchtop	Aftermarket service	Medium crimping force, small/medium sizes, limited productivity	
	MB 137 EVO	Benchtop	Aftermarket service	Medium crimping force, small/medium sizes, limited productivity	
	MB 240 EVO	Benchtop	Aftermarket service	Medium crimping force, medium productivity	
	MB 350 EVO / MB 350 EVO L	Benchtop: very high crimp force	Aftermarket service	High crimping force, medium productivity, large size	
	GOLDENCRIMP 420 EVO	Benchtop	Field maintenance shops, wide hose range	Very high crimping force, tough environments, large size	
	GOLDENCRIMP 450	Benchtop	Field maintenance shops, wide hose range	Very high crimping force, tough environments, large size	
	MRV 137 EVO R	Field service and mobile workshop	On site repair mobile van	Medium crimping force, limited productivity	
	MV 137 L	Field service and mobile workshop	On site repair mobile van	Medium crimping force, limited productivity	
	MV 240	Field service and mobile workshop	On site repair mobile van	Medium crimping force, limited productivity	

	MODEL	MACHINE TYPE	APPLICATION SECTOR	MACHINE PERFORMANCE	PAGE
CRIMPING	MV 240 L	Field service and mobile workshop	On site repair mobile van	Medium crimping force, limited productivity	
	MV 350 / MV 350 L	Field service and mobile or container workshop	On site repair mobile van	High crimping force, limited productivity, large size	
	MS 140	Stand-type crimp machine	Assembling production unit, small/medium sizes	Medium crimping force, high productivity for small - medium bore	
	MS 320	Stand-type crimp machine, SCS control	Assembling production unit, OEM and distribution	High crimping force, high productivity, large size	
	MS 480	Stand-type crimp machine, SCS control	Assembling production unit, OEM and large bore focus	Very high crimping force, high productivity, very large opening	
	MS 800	Stand-type crimp machine, SCS control	Assembling production unit	Very high crimping force for large bore hose focus	
	MS 320 OPEN HEAD	Stand-type crimp machine	Assembling production unit	High crimping force for large bore hose focus	
	MS 450-200	Stand-type crimp machine	Assembling production unit	Very high crimping force for large bore hose focus	
	MS 550 / MS 550-16	Stand-type crimp machine, SCS control	Assembling production unit	Very high crimping force for large bore hose focus	
TEST BENCHES	MTB 2000 L	Stand type machine; proof pressure and certify	Production unit	Wide hose range capacity	
	MTB 2000 XL	Stand type machine; proof pressure and certify	Production unit	Wide hose range capacity	
DIE SETS	DIE SETS FOR CRIMPING MACHINES				

In order to simplify the process of selecting appropriate equipment for new workshops, Manuli Hydraulics also offers a range of scaled machine modules. These modules include suitable combinations of cutting and crimping machines (and skiving where appropriate), based on the scale and planned throughput of the intended assembly operation.

MODULE	DESCRIPTION	CAPACITY	CUTTING	SKIVING	CRIMPING
	Small Service Workshop	1¼" 4WS 25 Hoses / Day Mixed sizes	M 22 CUT	M 50 SKY	MB 137 EVO
			M 22 CUT (12/24 V)	MH SKY	MRV 137 EVO R (12V)
	Intermittent Service Workshop	<ul style="list-style-type: none"> • 2" 4WS • 50 Hoses / Day • Mixed sizes 	M 30 CUT L	M 50 SKY	MB 240 EVO
					MV 240 EVO (12/24 V or 220 1Ph)
	Continuous Service Workshop	2" 6WS - 3" 2WB 100 Hoses / Day Mixed sizes	M 75 CUT	M 205 SKY PLUS	MB 350 EVO
					MV 350 (12/24 V or 220 1Ph/3Ph) or GoldenCrimp/450
	OEM Assembly Workshop	<ul style="list-style-type: none"> • 1¼" 4WS - 2" 2WB • >100 Hoses / Day • Mixed sizes 	M 55 CUT P	M 300 SKY	MS 140 SCS
	OEM Assembly Workshop	2" 4WS - 3" 2WB >100 Hoses / Day Mixed sizes	M 55 CUT P	M 300 SKY	MS 320
	OEM Assembly Workshop	<ul style="list-style-type: none"> • 2" 6WS - 3" 4WS • >100 Hoses / Day • Mixed sizes 	M 90 CUT	M 205 SKY <i>(With reinforced clamping system)</i>	MS 480
	XXL Assembly Workshop	3" 8WS - 4" 4WS - 8" Industrial Hose 50 Hoses / Day Mixed sizes	MDH 15 CUT	MDH 205 SKY	MS 550 / MS 800

Maintenance Operations

Intended for small or medium aftermarket, repair service

Production Operations

Intended for small/medium/large OEM activity or large production aftermarket

MODULE		DESCRIPTION	CAPACITY	CUTTING	ACCESSORIES	CRIMPING
		Industrial Workshop	<ul style="list-style-type: none"> Industrial hose up to 6" 	M75 CUT / MDH 15 CUT	Insert Pushing Decoiler	MS 320 OPEN HEAD
		Industrial Workshop	Industrial hose 4" & 6" 2wb : 4" max 4ws : 3" max 6ws : 2" max	M75 CUT / M90 CUT / MDH15 CUT	Insert Pushing Decoiler	MS 450-200

M 22 CUT / MV 22 CUT

STARTER WORKSHOP
BENCHTOP



KEY FEATURES

- Smooth bending system
- 90° cut
- Clean cut
- Scalloped blade
- Dust collector included
- Multiple voltage options

TECHNICAL SPECIFICATIONS

CAPACITY	DIMENSIONS
2wb: 1¼" max.	630 x 485 x 650 mm
4ws: 1¼" max.	(25 x 19 x 26 ")
ROTATION SPEED	PACKAGING
3000 rpm	800 x 600 x 830 mm
SCALLOPED BLADE DIAMETER	(31 x 24 x 33")
254 mm (10") included	NET WEIGHT
MAX HOSE OD.	42 kg (93 lb)
50 mm (1.969")	GROSS WEIGHT
MOTOR	55 kg (121 lb)
2.2 kW	TECHNICAL FEATURES
VOLTAGES	Dimensions van type machine:
220/240 V, 3Ph, 50 Hz	488 x 630 x 650 mm
380/415 V, 3Ph, 50 Hz	(19.2 x 24.8 x 25.6");
208/240 V, 3Ph, 60 Hz	38 kg (84 lb)
380/415 V, 3Ph, 60 Hz	
12/24 V also available upon request	

STANDARD



Scalloped Blade



Dust Collector

OPTIONAL



Battery & Charger

M 30 CUT E

STARTER & PROFESSIONAL WORKSHOP
BENCHTOP CUTTING MACHINE, OPTIONAL SKIVING



KEY FEATURES

Compact design

Easy and safe to use

Versatile, scalloped blade for high performance and efficient cutting with minimal smoke

Electronic brake

Skiving module can be ordered as optional and integrated on this machine

MACHINES
534

TECHNICAL SPECIFICATIONS

CAPACITY

2wb: 2" max.

4ws: 2" max.

6ws: 1¼" max.

Industrial: 2" max.

VOLTAGES

220/240 V, 3Ph, 50 Hz

380/415 V, 3Ph, 50 Hz

208/240 V, 3Ph, 60 Hz

380/415 V, 3Ph, 60 Hz

ROTATION SPEED

3000 rpm

DIMENSIONS

835 x 545 x 640 mm

(33 x 21 x 25")

SCALLOPED BLADE DIAMETER

300 mm (11.8")

MAX HOSE OD.

85 mm (3.346")

PACKAGING

1170 x 770 x 1100 mm

(46 x 30 x 43")

MOTOR

2.2 kW

NET WEIGHT

75 kg (165 lb)

GROSS WEIGHT

90 kg (198 lb)

STANDARD



Scalloped Blade



Dust Collector

OPTIONAL



Cutting Rail

M 30 CUT & SKIVE

STARTER & PROFESSIONAL WORKSHOP
BENCHTOP, INTEGRATED CUTTING & SKIVING



KEY FEATURES

- Compact design
- Two operations in one machine
- Easy and safe to use
- Versatile, scalloped blade for high performance and efficient cutting with minimal smoke
- Dust free skive operation (drawers for dust collection)
- Electronic brake

TECHNICAL SPECIFICATIONS

CAPACITY

2wb: 2" max.
4ws: 2" max.
6ws: 1¼" max.
Industrial: 2" max.

VOLTAGES

220/240 V, 3Ph, 50 Hz
380/415 V, 3Ph, 50 Hz
208/240 V, 3Ph, 60 Hz
380/415 V, 3Ph, 60 Hz

ROTATION SPEED (CUT)

3000 rpm

DIMENSIONS

835 x 545 x 640 mm
(33 x 21 x 25")

ROTATION SPEED (SKIVE)

200 rpm

PACKAGING

1170 x 770 x 1100 mm
46 x 30 x 43"

SCALLOPED BLADE DIAMETER

300 mm (11.8")

MAX HOSE OD.

85 mm (3.34")

NET WEIGHT

85 kg (187 lb)

MOTOR

2.2 kW

GROSS WEIGHT

100 kg (220 lb)

TECHNICAL FEATURES

Skiving tools for External Skiving (ESE) and for Internal Skiving (IS) to be ordered separately

STANDARD



Scalloped Blade



Dust Collector

OPTIONAL



Cutting Rail



Tool Kit ESE



Tool Kit iS

M 30 CUT L

STARTER & PROFESSIONAL WORKSHOP STAND TYPE CUTTING MACHINE



KEY FEATURES

- Compact design
- Easy and safe to use
- Versatile, scalloped blade for high performance and efficient cutting with minimal smoke
- Ergonomic, easy to clean
- Integrated dust collector

MACHINES 536

TECHNICAL SPECIFICATIONS

CAPACITY

2wb: 2" max.
4ws: 2" max.
6ws: 1¼" max.
Industrial: 2"

VOLTAGES

220/240 V, 3Ph, 50 Hz
380/415 V, 3Ph, 50 Hz
208/240 V, 3Ph, 60 Hz
380/415 V, 3Ph, 60 Hz

ROTATION SPEED

3000 rpm

DIMENSIONS

765 x 500 x 1150 mm
(30 x 20 x 45")

SCALLOPED BLADE DIAMETER

254 mm (10")

PACKAGING

800 x 600 x 1200 mm
(32 x 24 x 47")

MAX HOSE OD.

85 mm (3.34")

MOTOR

3.0 kW

NET WEIGHT

92 kg (203 lb)

GROSS WEIGHT

120 kg (265 lb)

STANDARD



Smoke Suction Connector

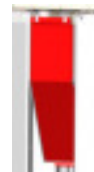

2 Dust Collectors



Scalloped Blade



Slotted Blade

OPTIONAL



Cutting Rail

M 55 CUT

FULL SERVICE WORKSHOP, STARTER PRODUCTION UNITS
STAND TYPE CUTTING MACHINE

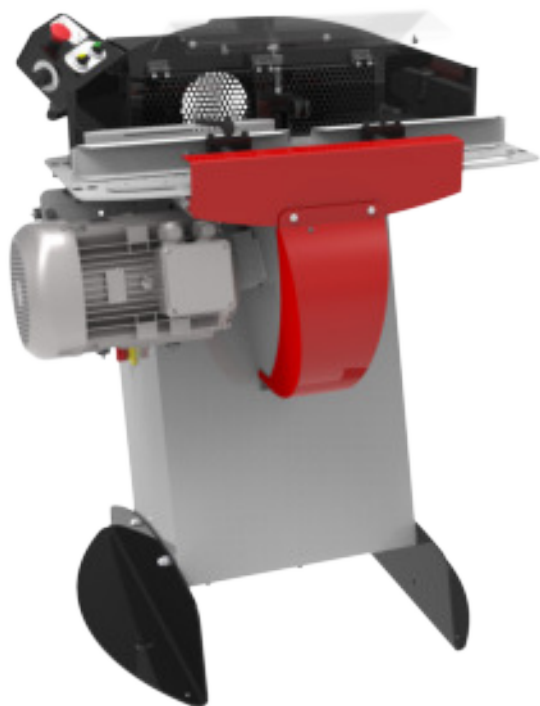

KEY FEATURES

- Versatile, slotted blade for high performance smoke free cutting
- Ergonomic and functional design
- Double foot pedal system
- Safety cover and feeding guides for hose (easy and fast cutting operation)
- Digital counter for maintenance assistance
- Adjustable speed for cutting on pneumatic version

TECHNICAL SPECIFICATIONS

CAPACITY

- 2wb: 2" max.
- 4ws: 2" max.
- 6ws: 2" max.
- Industrial: 2"

ROTATION SPEED

3000 rpm

SLOTTED BLADE DIAMETER

400 mm (15.7")

MAX HOSE OD.

80 mm (3.15")

MOTOR

7.5 kW

VOLTAGES

- 220/240 V, 3Ph, 50 Hz
- 380/415 V, 3Ph, 50 Hz
- 208/240 V, 3Ph, 60 Hz
- 380/415 V, 3Ph, 60 Hz

DIMENSIONS

1140 x 1000 x 1280 mm
(45 x 39 x 50")

PACKAGING

1600 x 1200 x 1600 mm
(63 x 47 x 63")

NET WEIGHT

240 kg (529 lb)

GROSS WEIGHT

280 kg (617 lb)

TECHNICAL FEATURES

Diameter of the suction connection: 150 mm (6")

Options: Pneumatic bending system, scalloped blade

STANDARD



Control Panel



Slotted Blade



Feeding Guide



Dust Collector

OPTIONAL



Cutting Rail



Smoke Suction



Decoiler



DV 32



DVC

M 75 CUT

EXPERT SERVICE LINE
STAND TYPE CUTTING MACHINE



KEY FEATURES

- Powerful
- Safety cover
- High visibility
- Suitable for cutting large bore hoses

STANDARD



Slotted Blade

TECHNICAL SPECIFICATIONS

CAPACITY

- 2wb: 3" max.
- 4ws: 2" max.
- 6ws: 2" max.

ROTATION SPEED

3000 rpm

SLOTTED BLADE DIAMETER

520 mm (20.5") included

MAX HOSE OD.

125 mm (5")

MOTOR

7.5 kW

VOLTAGES

- 220/240 V, 3Ph, 50 Hz
- 380/415 V, 3Ph, 50 Hz
- 208/240 V, 3Ph, 60 Hz
- 380/415 V, 3Ph, 60 Hz

DIMENSIONS

910 x 820 x 1280 mm
(36 x 32 x 50")

NET WEIGHT

215 kg (474 lb)

TECHNICAL FEATURES

Diameter of suction connection: 110 mm (4.33 ")

Optional tool: Brake motor, slotted disc

OPTIONAL



Cutting Rail



Decoiler



DV 32

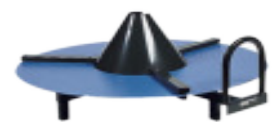

DVC

M 90 CUT

EXPERT SERVICE LINE
STAND TYPE CUTTING MACHINE



KEY FEATURES

- Very powerful
- Heavy duty for difficult cuts
- Hydraulic bending
- Brake motor
- Electronic soft start
- Smoke suction integrated in cutting table

STANDARD



Slotted Blade



Production Counters



Smoke Suction Connector



CME Electrical Foot Switch

TECHNICAL SPECIFICATIONS

CAPACITY

2wb: 3½" max.

4ws: 3½" max.

6ws: 3" max.

ROTATION SPEED

3000 rpm

SLOTTED BLADE DIAMETER

520 mm (20.5") included

MAX HOSE OD.

125 mm (5")

MOTOR

9.0 kW

VOLTAGES

220/240 V, 3Ph, 50 Hz

380/415 V, 3Ph, 50 Hz

208/240 V, 3Ph, 60 Hz

380/415 V, 3Ph, 60 Hz

DIMENSIONS

1000 x 1060 x 1350 mm
(39 x 42 x 53")

NET WEIGHT

260 kg (573 lb)

TECHNICAL FEATURES

Diameter of suction connection: 110 mm (4.33")

Standard tool: Hydraulic bending, brake motor

Optional tool: Slotted disc

OPTIONAL



Cutting Rail



Decoiler



DV 32

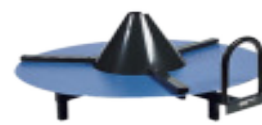

DVC

ACCESSORIES AND TOOLS

CUTTING DISCS

SCALLOPED BLADE TYPE

The scalloped blade is suitable for all hose types. It is able to reach a high quality of cutting surface and is the standard on 254 and 300 mm blades.

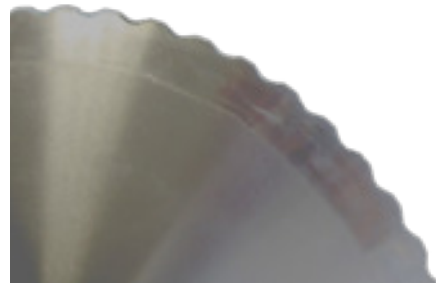

SLOTTED BLADE TYPE

The slotted blade is recommended for cutting standard and heavy duty hoses. It is ideal for continuous service, as the blade profile has been optimised to maintain a low temperature on the cutting edge. This blade provides an extended operational life of up to 2 times that of the previous blade, and is the standard on 400 and 520 mm blades.

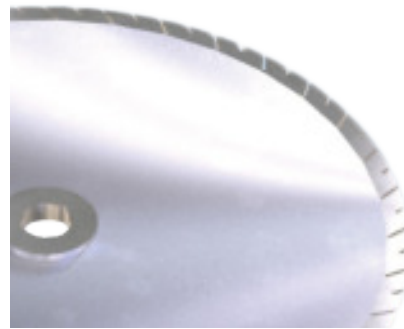

BRAKE MOTOR

The brake motor is a device which stops the disc immediately when the stop button is pushed.

PNEUMATIC BENDING

Available on M 75 CUT and M 55 CUT.

Pneumatic bending facilitates cutting, as the operator does not have to force the hose on the blade. The pneumatic system, activated by a foot switch, offers hands free operation. This is the same principle for the hydraulic bending on M 90 CUT.

KEY FEATURES

- Portable, lightweight
- Economic
- Simple
- Compact
- Robust
- Plug-in skive system



TECHNICAL SPECIFICATIONS

CAPACITY

2wb: 2" max.

4ws: 2" max.

DIMENSIONS

413 x 52 x 224 mm

(16 x 2 x 9")

NET WEIGHT

3 kg (7 lb)

TECHNICAL FEATURES

Tool selection:

- External Skiving Kit (ESE)
including 10 mandrels
(6-8-10-13-16-19-25-32-
38-50)

- Internal Skiving Kit (IS)
including 7 mandrels (13-
16-19-25-32-38-50)

Internal skiving tools can also
be ordered per diameter

OPTIONAL



Tool Kit ESE



Tool Kit IS

M 50 SKY

SMALL SERVICE WORKSHOP BENCHTOP SKIVING

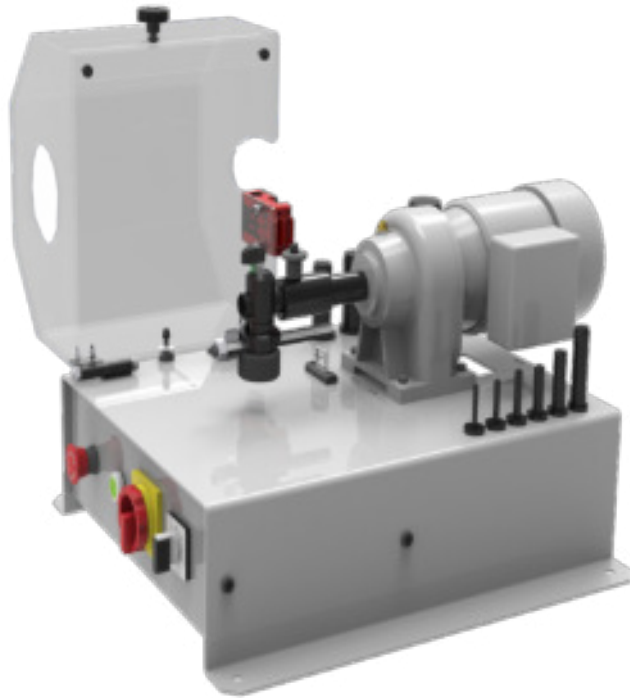

KEY FEATURES

- Plug'n skive system
- Compact & stable
- Safety switch on the cover
- Good visibility
- Tool storage included
- Foot pedal drive with emergency stop
- 2-way rotation

STANDARD



CME Electrical Foot Switch

TECHNICAL SPECIFICATIONS

CAPACITY

2wb: 2" max.

4ws: 2" max.

ROTATION SPEED

100 rpm

MOTOR

0.25 kW

VOLTAGES

220/240 V, 1Ph, 50 Hz

380/415 V, 3Ph, 50 Hz

220/240 V, 1Ph, 60 Hz

380/415 V, 3Ph, 60 Hz

DIMENSIONS

500 x 660 x 360 mm

(19 x 26 x 14")

PACKAGING

800 x 600 x 830 mm

(31 x 24 x 33")

NET WEIGHT

45 kg (99 lb)

GROSS WEIGHT

55 kg (121 lb)

TECHNICAL FEATURES

Tools available (to be ordered separately)

ESE, IS, ESP1, ESP2

OPTIONAL



Tool Kit IS

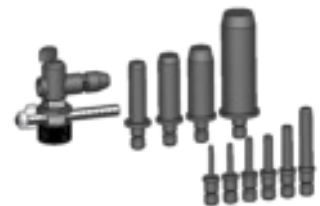

Tool Kit ESE

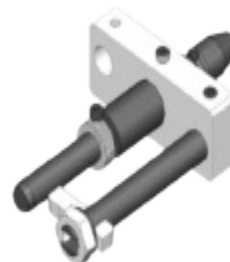

Tool Kit ESP 1

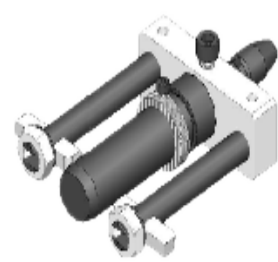

Tool Kit ESP 2

M 205 SKY

STARTER & PROFESSIONAL WORKSHOP STAND TYPE SKIVING MACHINE



KEY FEATURES

- Plug'n skive system
- Large dust collector
- Robust & easily adjustable knife for quick and easy changeover
- Suitable for high volume production
- 2-way rotation

TECHNICAL SPECIFICATIONS

CAPACITY

2wb: 3" max. with optional tools

4ws: 3" max. with optional tools

6ws: 3" max. with optional tools

ROTATION SPEED

205 rpm

MOTOR

0.9 kW

VOLTAGES

220/240 V, 3Ph, 50 Hz

380/415 V, 3Ph, 50 Hz

208/240 V, 3Ph, 60 Hz

380/415 V, 3Ph, 60 Hz

DIMENSIONS

675 x 550 x 1130 mm

(27 x 22 x 44")

PACKAGING

800 x 600 x 1200 mm

(32 x 24 x 47")

NET WEIGHT

100 kg (220 lb)

GROSS WEIGHT

160 kg (353 lb)

TECHNICAL FEATURES

Options available: speed regulator, hose clamping system (limited to distribution workshop using sizes under 2")

Tools available (to be ordered separately):
ESA, IS, ESP1, ESP2

OPTIONAL

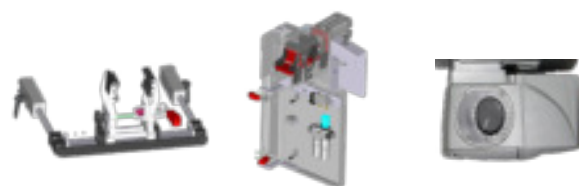

Manual Hose Clamping System

Pneumatic Hose Clamping System

Speed Regulator

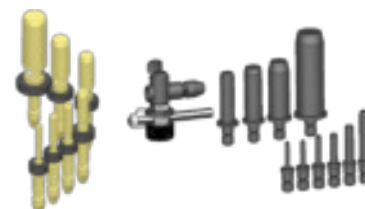

Tool Kit IS

Tool Kit ESE



Tool Kit ESP 1

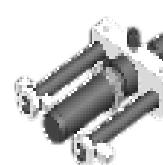

Tool Kit ESP 2

ACCESSORIES AND TOOLS

EXTERNAL SKIVING TOOLS

Depending on the machine and on customer needs, Manuli Hydraulics offers 3 types of external skiving tools:

ESE (External Skiving Economic)

For MH SKY, M 50 SKY and M 30 CUT & SKIVE

The ESE kit includes 10 mandrels: $\frac{1}{4}$ " , $\frac{5}{16}$ " , $\frac{3}{8}$ " , $\frac{1}{2}$ " , $\frac{5}{8}$ " , $\frac{3}{4}$ " , 1" , 1 $\frac{1}{4}$ " , 1 $\frac{1}{2}$ " , 2"

ESA (External Skiving Adjustable)

For M 205 SKY

The ESA kit includes 11 mandrels: $\frac{3}{16}$ " , $\frac{1}{4}$ " , $\frac{5}{16}$ " , $\frac{3}{8}$ " , $\frac{1}{2}$ " , $\frac{5}{8}$ " , $\frac{3}{4}$ " , 1" , 1 $\frac{1}{4}$ " , 1 $\frac{1}{2}$ " , 2"

ESA mandrels are also available in 2 $\frac{1}{2}$ " and 3"

ESP (External Skiving Production)

For M 50 SKY and M 205 SKY

ESP tools are individual 'skiving heads' intended to be pre-set to the right depth and length for greater productivity. They are recommended for batch skiving operations and a second knife can be added for abrasion resistant covers.

ESP is available in: $\frac{3}{16}$ " , $\frac{1}{4}$ " , $\frac{5}{16}$ " , $\frac{3}{8}$ " , $\frac{1}{2}$ " , $\frac{5}{8}$ " , $\frac{3}{4}$ " , 1" , 1 $\frac{1}{4}$ " , 1 $\frac{1}{2}$ " , 2" , 2 $\frac{1}{2}$ " and 3"

INTERNAL SKIVING TOOLS

IS (Internal Skiving)

For all machines

The IS kit includes 7 mandrels: $\frac{1}{2}$ " , $\frac{5}{8}$ " , $\frac{3}{4}$ " , 1" , 1 $\frac{1}{4}$ " , 1 $\frac{1}{2}$ " , 2"

They are also available in $\frac{5}{8}$ " , 2 $\frac{1}{2}$ " and 3"

The ring is heat treated to resist the abrasion of the hose wires.

Optional venturi system with IS tool.

ACCESSORIES AND TOOLS

HOSE CLAMPING SYSTEM

Recommended for skiving hoses over 2" (DN 50)

PLUG N'SKIVE SYSTEM

All Manuli Hydraulics skiving machines are equipped with the Plug'n Skive System which allows the quick and easy insertion of tools.

With the Plug n'Skive System no tools are needed to insert the skiving mandrel, simply push the mandrel into the locking system to unlock it, lift a knob and pull out the tool.

M 1500 INS

EXPERT SERVICE LINE
BENCHTOP COUPLING INSERTER

KEY FEATURES

- Compact
- Sturdy
- Powerful
- Hydro pneumatic power pack

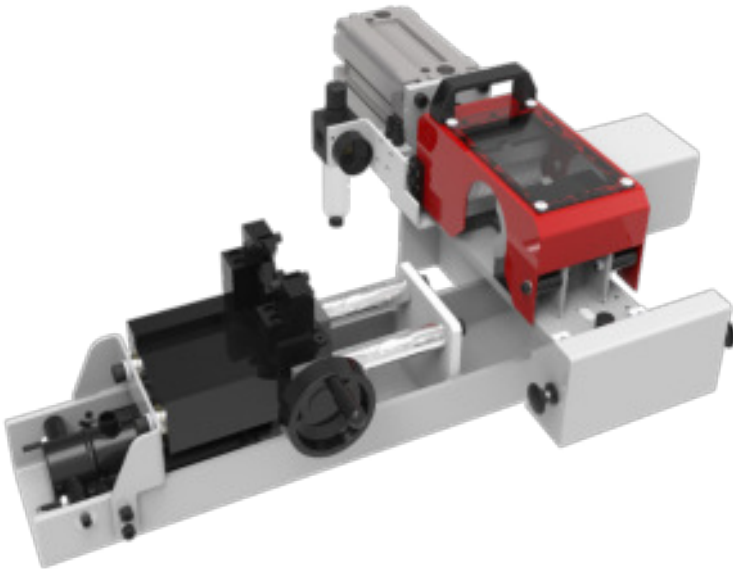

TECHNICAL SPECIFICATIONS

CAPACITY

2wb: 2" max.

4ws: 2" max.

6ws: 2" max.

DIMENSIONS

750 x 660 x 300 mm

(30 x 26 x 12")

NET WEIGHT

70 kg (154 lb)

POWER SUPPLY

Compressed air (7 bar)

TECHNICAL FEATURES

Optional tool: for small bore
1/4", 3/8", 1/2" shell

STANDARD



Hydro-pneumatic Pump

M 4000 INS

EXPERT SERVICE LINE
BENCHTOP COUPLING INSERTER

KEY FEATURES

- Compact
- Sturdy
- Powerful
- Manual insert centring device
- Joystick operated clamping and insertion

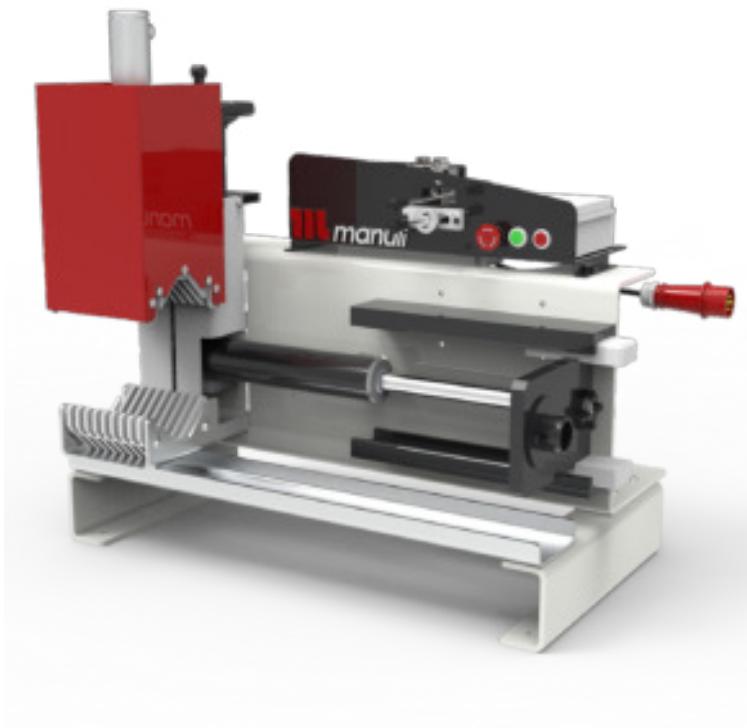

TECHNICAL SPECIFICATIONS

CAPACITY

76 mm - 170 mm OD Hose

DIMENSIONS

800 x 500 x 900 mm

(31 x 20 x 35")

NET WEIGHT

150 kg (330 lb)

VOLTAGES

380/415 V, 3Ph, 50 Hz

POWER

1.5kW

MAXIMUM FLANGE

250 mm

INSERTION FORCE

4,000 N

INSERTION STROKE

300 mm

INSERTION SPEED *

24 mm/s

CLAMPING LENGTH

200 mm

OPTIONS

Manual version available



* Electrical version only

M 50 MARK

AFTER MARKET SERVICE
BENCHTOP, FERRULE MARKING

KEY FEATURES

- Robust
- Easy to use
- Compact
- Large space for 14 stamps
- Stamp holder with numbering wheel; 3 figures on the wheel + 1 groove for stamps



TECHNICAL SPECIFICATIONS

CAPACITY

2wb: 4" max.

4ws: 4" max.

DIMENSIONS

390 x 360 x 520 mm

(15 x 14 x 20")

PACKAGING

800 x 600 x 830 mm

(31 x 24 x 33")

NET WEIGHT

34 kg (75 lb)

GROSS WEIGHT

50 kg (110 lb)

STANDARD STAMP HOLDER

2 x 14 stamps

SIZE OF THE STAMPS

6 x 3 mm

(0.236 x 0.118")

HEIGHT OF THE LETTERS

2.5 mm

(0.098")

TECHNICAL FEATURES

Optional stamp holder with numbering wheel: 3 figures on the wheel and one groove for 10 stamps

STAMP BOX

Includes stamp box of 100 stamps & 20 blanks

CK 50



TECHNICAL SPECIFICATIONS

NUMBER OF NOZZLES

10 to suit hose ID

COMPRESSED AIR

7 bar

MINIMUM INTERNAL DIAMETER OF HOSE

6 mm

MINIMUM INTERNAL DIAMETER

51 mm

TECHNICAL FEATURES

Includes 575 pellets & projectile catcher

HRD 07

HOSES CAN BE STORED ON THE HOSE DISPENSER



TECHNICAL SPECIFICATIONS

MAXIMUM NUMBER OF COILS

7

MAXIMUM WEIGHT/COIL

80 kg

MINIMUM INTERNAL DIAMETER

300 mm

MINIMUM EXTERNAL DIAMETER

850 mm

MAXIMUM HEIGHT

200 mm

DIMENSIONS

1180 x 1180 x 2115 mm (100 kg)

PACKAGING

1200 x 1200 x 720 mm (135 kg)

DV 32 - DVC - OEM DECOILER

DV 32



DVC



OEM



The hose decoiler is highly adaptable, suitable for a hose reel or a coil up to 100 kgs. It is stable and equipped with a hose guide system and a manual break, offering increased safety and efficiency.

INDUSTRIAL DECOILER

Robust, motorised decoiler for large bore industrial hose. Comes with 6 manually adjustable centring pins, remote stop-start controller and a high torque, 3kW motor with speed control.



VOLTAGES

400 V, 3Ph, 50 Hz

DIMENSIONS

2600 x 2600 x 1600 mm

(102 x 102 x 63")

NET WEIGHT

714 kg (1570 lb)

MOTOR

3 kW with speed control

POWER TORQUE

1200 N

TABLE DIAMETER

2200 mm

MHP 80

FIELD SERVICE & MOBILE WORKSHOP
HAND PUMP, PORTABLE



KEY FEATURES

- Compact
- Lightweight
- Easy to use
- Balanced design
- Dual stage pump
- 1" Die Set included

OPTIONAL



Maintenance Kits



Hydro-pneumatic Pump

TECHNICAL SPECIFICATIONS

CRIMP RANGE

4 - 43 mm (0.157 - 1.693")

CRIMP FORCE

80 t

OPENING WITH DIES

+20 mm (+0.787")

COMPLETE OPENING

59 mm (2.323")

MASTER DIE LENGTH

56 mm (2.205")

STANDARD DIES

15, 18, 21, 24, 27, 30, 39

DIMENSIONS

330 x 250 x 400 mm

(13 x 10 x 16")

PACKAGING

800 x 600 x 830 mm

(31 x 24 x 33")

NET WEIGHT

28 kg (62 lb)

GROSS WEIGHT

41 kg (90 lb)

TECHNICAL FEATURES

Hand pump: 5000 psi
(double speed)

HOSE AND FITTINGS SELECTION

HOSE TYPE	FITTING TYPE	MAX HOSE SIZE
2 WIRE BRAID & TEXTILE	MF2000 MULTIFIT; MF3000 OPK; MF3000 OPF	1"
3 WIRE (1 BRAID + 2 SPIRAL)	MF2000 MULTIFIT	½"
4 WIRE SPIRALS	MF2000 MULTIFIT; MF3000 OPK	½"

MHP 110

FIELD SERVICE & MOBILE WORKSHOP
HAND PUMP, PORTABLE

KEY FEATURES

- Flexible
- Portable
- Robust (protected narrow head)
- Multi-positioning (with removable plate)

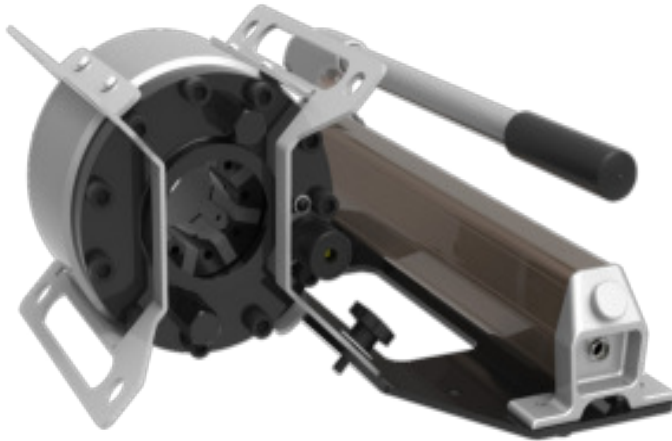

OPTIONAL



Maintenance Kits



Hydro-pneumatic Pump

TECHNICAL SPECIFICATIONS

CRIMP RANGE

4 - 43 mm (0.157 - 1.693")

CRIMP FORCE

110 t

OPENING WITH DIES

+20 mm (+0.787")

COMPLETE OPENING

59 mm (2.323")

MASTER DIE LENGTH

60 mm (2.362")

STANDARD DIES

15, 18, 21, 24, 27, 30

DIMENSIONS

220 x 222 x 240 mm

(7 x 9 x 10")

PACKAGING

800 x 600 x 830 mm

(31 x 24 x 33")

NET WEIGHT

28 kg (62 lb)

WEIGHT (HEAD ONLY)

21 kg (46 lbs)

HOSE AND FITTINGS SELECTION

HOSE TYPE	FITTING TYPE	MAX HOSE SIZE
2 WIRE BRAID & TEXTILE	MF2000 MULTIFIT; MF3000 OPK; MF3000 OPF	1"
3 WIRE (1 BRAID + 2 SPIRAL)	MF2000 MULTIFIT	¾"
4 WIRE SPIRALS	MF2000 MULTIFIT; MF3000 OPK	1"

MHP 137

FIELD SERVICE & MOBILE WORKSHOP HAND PUMP, PORTABLE

KEY FEATURES

- High capacity
- Narrow head
- Audio-visual signal
- 350 bar technology more robust & reliable than 700 bar
- Large opening



OPTIONAL



Maintenance Kit



Quick Change Gun



Aluminium Quick Change Gun

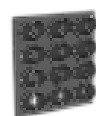

Die Storage Panel



Hydro-pneumatic Pump



Marking Dies



Die Sets for Brake & Air Conditioning Hoses

TECHNICAL SPECIFICATIONS

CRIMP RANGE

4 - 70 mm (0.157 - 2.756")

CRIMP FORCE

137 t

OPENING WITH DIES

+28 mm (+1.102")

COMPLETE OPENING

100 mm (3.937")

MASTER DIE LENGTH

75 mm (2.362")

STANDARD DIES

15, 18, 21, 24, 27, 30, 33, 36, 39, 42, 45, 48, 51 and Refrifast dies 14, 18, 21

DIMENSIONS

480 x 250 x 340 mm
(19 x 10 x 13")

PACKAGING

800 x 600 x 830 mm
(31 x 24 x 33")

NET WEIGHT

55 kg (121 lb)

GROSS WEIGHT

75 kg (165 lb)

HOSE AND FITTINGS SELECTION

HOSE TYPE	FITTING TYPE	MAX HOSE SIZE
2 WIRE BRAID & TEXTILE	MF2000 MULTIFIT; MF3000 OPF; MF3000 OPK	1 ¼"
3 WIRE (1 BRAID + 2 SPIRAL)	MF2000 MULTIFIT;	1 ¼"
4 WIRE SPIRALS	MF2000 MULTIFIT; MF3000 OPK	1 ¼"
3 WIRE (1 BRAID + 2 SPIRAL)	MF2000 INTERLOCK PLUS; MF2000 SPIRALFIT	¾"
4 WIRE SPIRALS	MF2000 INTERLOCK PLUS; MF2000 SPIRALFIT	¾"

MRB 137 EVO R

MAINTENANCE WORKSHOP VERTICAL BENCHTOP

KEY FEATURES

- Ergonomically positioned adjustable head
- Axis of the head situated perpendicular to the operator
- Compact
- Optional quick change tool for dies
- Range of standard dies available



OPTIONAL



Maintenance Kit

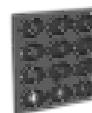

Die Storage Panel



Die Storage Table



Quick Change Gun



Aluminium Quick Change Gun



Die Storage Panel EVO R

TECHNICAL SPECIFICATIONS

CRIMP RANGE

6 to 56 mm (0.517 - 2.205")

CRIMP FORCE

137 t

OPENING WITH DIES

+28 mm (+1.102")

COMPLETE OPENING

100 mm (3.937")

MASTER DIE LENGTH

75 mm (2.953")

STANDARD DIES

15, 18, 21, 24, 27, 30, 33, 36, 39, 42, 45, 48, 51

NOISE LEVEL

70 dB A

MOTOR

1.5 kW (110V)

2.2 kW (230V)

VOLTAGES

110 V, 1Ph, 60 Hz

220/240 V, 1 Ph, 50 Hz

380/415V, 3 Ph + N, 50 Hz

+12/24

Other voltages available on request

DIMENSIONS

360 x 530 x 620 mm

(14 x 21 x 25")

NET WEIGHT

85 kg (187 lb)

GROSS WEIGHT

89 kg (196 lb)

HOSE AND FITTINGS SELECTION

HOSE TYPE	FITTING TYPE	MAX HOSE SIZE
2 WIRE BRAID & TEXTILE	MF2000 MULTIFIT; MF3000 OPF; MF3000 OPK	1 ¼"
3 WIRE (1 BRAID + 2 SPIRAL)	MF2000 MULTIFIT	1 ¼"
4 WIRE SPIRALS	MF2000 MULTIFIT; MF3000 OPK	1 ¼"
3 WIRE (1 BRAID + 2 SPIRAL)	MF2000 INTERLOCK PLUS; MF2000 SPIRALFIT	¾"
4 WIRE SPIRALS	MF2000 INTERLOCK PLUS; MF2000 SPIRALFIT	¾"

MB 137 EVO

ASSEMBLING FOR FIELD REPAIR BENCHTOP CRIMP MACHINE



KEY FEATURES

- Crimp force of up to 137 tonnes for hoses up to 1 1/4"
- Easy to use and robust
- Extensive range of dies to suit crimping of hydraulic hoses
- Easy to set up and maintain
- Fast and reliable
- Numerical micrometer
- Model shown equipped with SC control panel
- Calliper option on SCE control panel
- Bluetooth as standard on SC and SCE control panels



CONTROL OPTIONS AVAILABLE ON REQUEST



SC

SCE

SCS

TECHNICAL SPECIFICATIONS

CRIMP RANGE

4 - 70 mm (0.157 - 2.756")

CRIMP FORCE

137 t

OPENING WITH DIES

+28 mm (+1.102")

COMPLETE OPENING

100 mm (3.937")

MASTER DIE LENGTH

75 mm (2.953")

STANDARD DIES

15, 18, 21, 24, 27, 30, 33, 36, 39, 42, 45, 48, 51

NOISE LEVEL

70 dB A

MOTOR

4.0 kW

VOLTAGES

220/240 V, 3Ph, 50 Hz

380/415 V, 3Ph, 50 Hz

208/240 V, 3Ph, 60 Hz

380/415 V, 3Ph, 60 Hz

Other voltages available on request

DIMENSIONS

765 x 400 x 650 mm

(30 x 16 x 26")

NET WEIGHT

160 kg (353 lb)

OPTIONAL



Maintenance Kit



Marking Dies

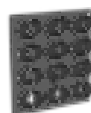

Die Storage Panel



Die Storage Table



Electrical Footswitch



Quick Change Gun



Aluminium Quick Change Gun



Die Sets for Brake & Air Conditioning Hoses

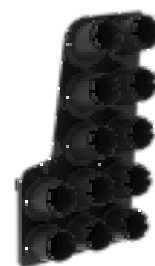

Die Storage Panel EVO

MB 137 EVO**ASSEMBLING FOR FIELD REPAIR
BENCHTOP CRIMP MACHINE****HOSE AND FITTINGS SELECTION**

HOSE TYPE	FITTING TYPE	MAX HOSE SIZE
2 WIRE BRAID & TEXTILE	MF2000 MULTIFIT; MF3000 OPF; MF3000 OPK	1 ¼"
3 WIRE (1 BRAID + 2 SPIRAL)	MF2000 MULTIFIT	1 ¼"
4 WIRE SPIRALS	MF2000 MULTIFIT; MF3000 OPK	1 ¼"
3 WIRE (1 BRAID + 2 SPIRAL)	MF2000 INTERLOCK PLUS; MF2000 SPIRALFIT	¾"
4 WIRE SPIRALS	MF2000 INTERLOCK PLUS; MF2000 SPIRALFIT	¾"

MB 240 EVO

PROFESSIONAL WORKSHOP BENCHTOP



KEY FEATURES

- Crimp force of up to 240 tonnes for hoses up to 2"
- Easy to use and robust
- Radial die movement
- High crimping force
- Extensive range of dies to suit crimping of hydraulic hoses
- Easy set up and maintenance
- Fast and reliable
- Numerical micrometer
- Model shown equipped with SCE control panel
- Calliper option on SCE control panel
- Bluetooth as standard on SC and SCE control panels



CONTROL OPTIONS AVAILABLE ON REQUEST



SC

SCE

SCS

TECHNICAL SPECIFICATIONS

CRIMP RANGE

4 - 76 mm (0.157 - 2.992")

CRIMP FORCE

240 t

OPENING WITH DIES

+38 mm (+1.496")

COMPLETE OPENING

118 mm (4.645")

MASTER DIE LENGTH

100 mm (3.937")

STANDARD DIES

15, 18, 21, 24, 27, 30, 33, 36, 39, 42, 45, 48, 51, 57, 62, 66, 70

NOISE LEVEL

<70 dB A

MOTOR

4.0 kW

VOLTAGES

220/240 V, 3Ph, 50 Hz

380/415 V, 3Ph, 50 Hz

208/240 V, 3Ph, 60 Hz

380/415 V, 3Ph, 60 Hz

Other voltages available on request

DIMENSIONS

765 x 400 x 650 mm

(30 x 16 x 26")

NET WEIGHT

165 kg (364 lb)

OPTIONAL



Maintenance Kit



Marking Dies

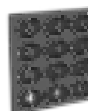

Die Storage Panel



Die Storage Table



Electrical Footswitch



Quick Change Gun



Aluminium Quick Change Gun



Mechanical Backstop



Die Sets for Brake & Air Conditioning Hoses



Die Storage Panel EVO

MB 240 EVO

PROFESSIONAL WORKSHOP BENCHTOP

HOSE AND FITTINGS SELECTION

HOSE TYPE	FITTING TYPE	MAX HOSE SIZE
2 WIRE BRAID & TEXTILE	MF2000 MULTIFIT; MF3000 OPF; MF3000 OPK	2"
3 WIRE (1 BRAID + 2 SPIRAL)	MF2000 MULTIFIT; MF2000 INTERLOCK PLUS; MF2000 SPIRALFIT	1 ¼"
4 WIRE SPIRALS	MF2000 MULTIFIT; MF3000 OPK	2"
4 WIRE SPIRALS	MF2000 INTERLOCK PLUS; MF2000 SPIRALFIT	1 ¼"
6 WIRE SPIRAL	MF2000 INTERLOCK PLUS;	1"

MB 350 EVO / MB 350 EVO L

FULL SERVICE WORKSHOP
BENCHTOP; VERY HIGH CRIMP FORCE



KEY FEATURES

- Crimp force of up to 350 tonnes for hoses up to 3"
- Easy to use and robust
- Automatic maintenance alerts
- Groove for 90° long drop fittings
- Also available as S CRIMP 350 L with 4.0 kW motor
- Numerical micrometer
- Model shown equipped with SCS control panel
- Calliper option on SCE control panel
- Bluetooth as standard on SC and SCE control panels



CONTROL OPTIONS AVAILABLE ON REQUEST



SC



SCE

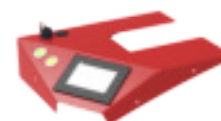

SCS

TECHNICAL SPECIFICATIONS

CRIMP RANGE

4 - 130 mm (0.157 - 5.118")

CRIMP FORCE

350 t

OPENING WITH DIES

+54 mm (+2.125")

COMPLETE OPENING

180 mm (7.086")

MASTER DIE LENGTH

115 mm (4.523")

STANDARD DIES

15, 18, 21, 24, 27, 30, 33, 36, 39, 42, 45, 48, 51, 57, 62, 66, 70, 73, 76

NOISE LEVEL

<70 dB A

MOTOR

5.5 kW / 4 kW

VOLTAGES

220/240 V, 3Ph, 50 Hz

380/415 V, 3Ph, 50 Hz

208/240 V, 3Ph, 60 Hz

380/415 V, 3Ph, 60 Hz

DIMENSIONS

765 x 400 x 750 mm

(30 x 16 x 30")

NET WEIGHT

262 kg (578 lb)

TECHNICAL FEATURES

- Automatic maintenance alerts
- Cylinder protection against dust - durable design
- Also available as S CRIMP 350 EVO L with 4.0 kW Motor

OPTIONAL



Maintenance Kit



Marking Dies

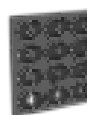

Die Storage Panel



Die Storage Table



Electrical Footswitch



Quick Change Gun



Aluminium Quick Change Gun



Mechanical Backstop



Die Sets for Brake & Air Conditioning Hoses



Die Storage Panel EVO

MB 350 EVO / MB 350 EVO L

**FULL SERVICE WORKSHOP
BENCHTOP; VERY HIGH CRIMP FORCE**

HOSE AND FITTINGS SELECTION

HOSE TYPE	FITTING TYPE	MAX HOSE SIZE
2 WIRE BRAID & TEXTILE	MF2000 MULTIFIT; MF3000 OPF; MF3000 OPK	3"
3 WIRE (1 BRAID + 2 SPIRAL)	MF2000 MULTIFIT; MF2000 INTERLOCK PLUS; MF2000 SPIRALFIT;	1 ¼"
4 WIRE SPIRALS	MF2000 MULTIFIT; MF2000 INTERLOCK PLUS; MF2000 SPIRALFIT; MF3000 OPK	2"
5 WIRE (4 SPIRAL + 1 BRAID)	MF2000 INTERLOCK PLUS	1 ¼"
7 WIRE (6 SPIRAL + 1 BRAID)	MF2000 INTERLOCK SUPER	1 ½"
6 WIRE SPIRALS (350 BAR / 5000psi)	MF2000 INTERLOCK PLUS; MF2000 SPIRALFIT	2"
6 WIRE SPIRAL (420 BAR / 5000psi)	MF2000 INTERLOCK PLUS; MF2000 INTERLOCK SUPER	1 ½"
8 WIRE SPIRALS	MF2000 INTERLOCK PLUS	1 ¼"

GOLDENCRIMP 420 EVO

ASSEMBLING FOR FIELD REPAIR BENCHTOP CRIMP MACHINE



KEY FEATURES

- High crimping force of 420 tonnes
- Robust design for transport and operation in harsh environments
- Protected cylinders for trouble-free operation in high dust environments
- Large opening suitable for large bore hoses
- Easy maintenance due to foam pads and dust collector
- Numerical micrometer
- Model shown equipped with SCS control panel
- Calliper option on SCE control panel
- Bluetooth as standard on SC and SCE control panels



CONTROL OPTIONS AVAILABLE ON REQUEST



SC

SCE

SCS

TECHNICAL SPECIFICATIONS

CRIMP RANGE

4 - 130 mm (0.157 - 5.118")

CRIMP FORCE

420 t

OPENING WITH DIES

+48 mm (+1.9 inch)

COMPLETE OPENING

178 mm (7.0 inch)

MASTER DIE LENGTH

120 mm (4.724 inch)

STANDARD DIES

15, 18, 21, 24, 27, 30, 33, 36, 39, 42, 45, 48, 51, 57, 62, 66, 70, 73, 76

NOISE LEVEL

<70 dB A

MOTOR

5.5 kW

VOLTAGES

220/240 V, 3Ph, 50 Hz

380/415 V, 3Ph, 50 Hz

208/240 V, 3Ph, 60 Hz

380/415 V, 3Ph, 60 Hz

DIMENSIONS

765 x 500 x 800 mm

(30 x 20 x 32")

PACKAGING

745 x 1150 x 945 mm

(29 x 45 x 37")

NET WEIGHT

395 kg (871 lb)

OPTIONAL



Maintenance Kit



Marking Dies

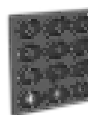

Die Storage Panel



Die Storage Table



Electrical Footswitch



Quick Change Gun



Aluminium Quick Change Gun



Die Sets for Brake & Air Conditioning Hoses



Die Storage Panel EVO

GOLDENCRIMP 420 EVO

ASSEMBLING FOR FIELD REPAIR
BENCHTOP CRIMP MACHINE

HOSE AND FITTINGS SELECTION

HOSE TYPE	FITTING TYPE	MAX HOSE SIZE
2 WIRE BRAID & TEXTILE	MF2000 MULTIFIT; MF3000 OPF; MF3000 OPK	4"
3 WIRE (1 BRAID + 2 SPIRAL)	MF2000 MULTIFIT; MF2000 INTERLOCK PLUS; MF2000 SPIRALFIT;	1 ¼"
4 WIRE SPIRALS	MF2000 MULTIFIT; MF3000 OPK; MF2000 INTERLOCK PLUS; MF2000 SPIRALFIT;	3"
5 WIRE (4 SPIRAL + 1 BRAID)	MF2000 INTERLOCK PLUS	1 ¼"
7 WIRE (6 SPIRAL + 1 BRAID)	MF2000 INTERLOCK SUPER	1 ½"
6 WIRE SPIRALS	MF2000 INTERLOCK SUPER; MF2000 SPIRALFIT-GX; MF2000 INTERLOCK PLUS; MF2000 SPIRALFIT	2"
8 WIRE SPIRALS	MF2000 INTERLOCK SUPER	1 ½"

GOLDENCRIMP 450

ASSEMBLING FOR FIELD REPAIR BENCHTOP CRIMP MACHINE



KEY FEATURES

- High crimp force (450 tonnes)
- Large opening
- Wide family of dies for industrial hoses
- Long master dies
- Robust - designed for harsh environments
- Low noise level
- Easy die set-up with ergonomic gun
- Metallic guard for the set stop

STANDARD



Electrical Footswitch

OPTIONAL

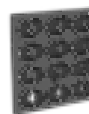

Die Storage Panel



Die Storage Table



Die Sets for Brake & Air Conditioning Hoses



Quick Change Gun



Aluminium Quick Change Gun



Marking Dies

TECHNICAL SPECIFICATIONS

CRIMP RANGE

4 - 130 mm (0.157 - 5.118")

CRIMP FORCE

450 t

OPENING WITH DIES

+70 mm (+2.755")

COMPLETE OPENING

197 mm (7.755")

MASTER DIE LENGTH

140 mm (5.512")

STANDARD DIES

15, 18, 21, 24, 27, 30, 33, 36, 39, 42, 45, 48, 51, 57, 62, 66, 70, 73, 76

NOISE LEVEL

<65 dB A

MOTOR

5.5 kW

VOLTAGES

220/240 V, 3Ph, 50 Hz

380/415 V, 3Ph, 50 Hz

208/240 V, 3Ph, 60 Hz

380/415 V, 3Ph, 60 Hz

DIMENSIONS

830 x 775 x 1450 mm

(33 x 31 x 57")

PACKAGING

1120 x 1020 x 1770 mm

(44 x 40 x 70")

NET WEIGHT

720 kg (1587 lb)

HOSE AND FITTINGS SELECTION

HOSE TYPE	FITTING TYPE	MAX HOSE SIZE
2 WIRE BRAID & TEXTILE	MF2000 MULTIFIT; MF3000 OPF; MF3000 OPK	4"
1 WIRE BRAID + 2 WIRE SPIRAL	MF2000 MULTIFIT; MF2000 INTERLOCK PLUS; MF2000 SPIRALFIT;	1 3/4"
4 WIRE SPIRALS	MF2000 MULTIFIT; MF3000 OPK; MF2000 INTERLOCK PLUS; MF2000 SPIRALFIT;	3"
5 WIRE (4 SPIRAL + 1 BRAID)	MF2000 INTERLOCK PLUS	1 3/4"
7 WIRE (6 SPIRAL + 1 BRAID)	MF2000 INTERLOCK SUPER	1 1/2"
6 WIRE SPIRALS	MF2000 INTERLOCK PLUS; MF2000 SPIRALFIT	3"
6 WIRE SPIRALS	MF2000 INTERLOCK SUPER; MF2000 SPIRALFIT-GX	2"
8 WIRE SPIRALS	MF2000 INTERLOCK SUPER	1 1/2"

MRV 137 EVO R

FIELD SERVICE & MOBILE WORKSHOP
MOBILE VAN

KEY FEATURES

- Ergonomically positioned adjustable crimping head
- Axis of crimping head oriented perpendicular to the operator
- Optional quick change tool for dies available in Plastic or Aluminium
- Compact design
- Range of standard dies available
- Optional die storage panel available

OPTIONAL



Maintenance Kit

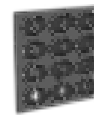

Die Storage Panel



Die Storage Table



Quick Change Gun



Die Storage Panel EVO R



Aluminium Quick Change Gun



TECHNICAL SPECIFICATIONS

CRIMP RANGE

6 - 56 mm (0.517 - 2.205")

CRIMP FORCE

137 t

OPENING WITH DIES

+28 mm (+1.102")

COMPLETE OPENING

100 mm (3.937")

MASTER DIE LENGTH

75 mm (2.952")

STANDARD DIES

15, 18, 21, 24, 27, 30, 33,
36, 39, 42, 45, 48, 51

NOISE LEVEL

70 dB A

MOTOR

1.5 kW (12V)

VOLTAGES

12 V

DIMENSIONS

470 x 630 x 644 mm
(19 x 25 x 25")

NET WEIGHT

89 kg (196 lb)

GROSS WEIGHT

105 kg (231 lb)

HOSE AND FITTINGS SELECTION

HOSE TYPE	FITTING TYPE	MAX HOSE SIZE
2 WIRE BRAID & TEXTILE	MF2000 MULTIFIT; MF3000 OPF; MF3000 OPK	1 ¼"
3 WIRE (1 BRAID + 2 SPIRAL)	MF2000 MULTIFIT	1 ¼"
4 WIRE SPIRALS	MF2000 MULTIFIT; MF3000 OPK	1 ¼"
3 WIRE (1 BRAID + 2 SPIRAL)	MF2000 INTERLOCK PLUS; MF2000 SPIRALFIT	¾"
4 WIRE SPIRALS	MF2000 INTERLOCK PLUS; MF2000 SPIRALFIT	¾"

MV 137 L

FIELD SERVICE & MOBILE WORKSHOP
MOBILE VAN



KEY FEATURES

- Robust and compact design
- Lightweight
- High crimping speed
- Suitable also for 90° elbow fittings
- Cylinder protection

OPTIONAL



Maintenance Kit



Quick Change Gun



Aluminium Quick Change Gun

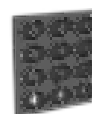

Die Storage Panel



Battery & Charger



Marking Dies



Die Sets for Brake & Air Conditioning Hoses



Front Die Storage

TECHNICAL SPECIFICATIONS

CRIMP RANGE

4 - 70 mm (0.157 - 2.756")

CRIMP FORCE

137 t

OPENING WITH DIES

+28 mm (+1.102")

COMPLETE OPENING

100 mm (3.937")

MASTER DIE LENGTH

75 mm (2.952")

STANDARD DIES

15, 18, 21, 24, 27, 30, 33, 36, 39, 42, 45, 48, 51

NOISE LEVEL

72 dB A

MOTOR

2.0 kW

VOLTAGES

12 V

24 V

DIMENSIONS

250 x 320 x 300 mm

(10 x 13 x 12")

PACKAGING

800 x 600 x 830 mm

(31 x 24 x 33")

NET WEIGHT

86 kg (190 lb)

GROSS WEIGHT

102 kg (225 lb)

TECHNICAL FEATURES

Dimensions of power pack:
440 x 320 x 320 mm
(17 x 13 x 13")

HOSE AND FITTINGS SELECTION

HOSE TYPE	FITTING TYPE	MAX HOSE SIZE
2 WIRE BRAID & TEXTILE	MF2000 MULTIFIT; MF3000 OPF; MF3000 OPK	1 ¼"
3 WIRE (1 BRAID + 2 SPIRAL)	MF2000 MULTIFIT	1 ¼"
4 WIRE SPIRALS	MF2000 MULTIFIT; MF3000 OPK	1 ¼"
3 WIRE (1 BRAID + 2 SPIRAL)	MF2000 INTERLOCK PLUS; MF2000 SPIRALFIT	¾"
4 WIRE SPIRALS	MF2000 INTERLOCK PLUS; MF2000 SPIRALFIT	¾"

MV 240

FIELD SERVICE & MOBILE WORKSHOP MOBILE VAN



KEY FEATURES

- Robust design
- Ergonomic micrometer
- High crimping speed
- Radial movement of the dies
- Cylinder protection
- Remote head mounting option possible

OPTIONAL



Maintenance Kit



Quick Change Gun



Aluminium Quick Change Gun

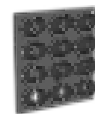

Die Storage Panel



Battery & Charger



Marking Dies



Die Sets for Brake & Air Conditioning Hoses



Front Die Storage

TECHNICAL SPECIFICATIONS

CRIMP RANGE

4 - 76 mm (0.157 - 2.992")

CRIMP FORCE

240 t

OPENING WITH DIES

+38 mm (+1.496")

COMPLETE OPENING

118 mm (4.646")

MASTER DIE LENGTH

100 mm (3.937")

STANDARD DIES

15, 18, 21, 24, 27, 30, 33, 36, 39, 42, 45, 48, 51, 57, 62, 66, 70

NOISE LEVEL

72 dB A

MOTOR

2.0 kW

VOLTAGES

12 V

24 V

220/240 V, 3Ph, 50 Hz

380/415 V, 3Ph, 50 Hz

208/240 V, 3Ph, 60 Hz

380/415 V, 3Ph, 60 Hz

DIMENSIONS

650 x 550 x 670 mm

(26 x 22 x 26")

PACKAGING

800 x 600 x 830 mm

(31 x 24 x 33")

NET WEIGHT

145 kg (320 lb)

GROSS WEIGHT

180 kg (397 lb)

HOSE AND FITTINGS SELECTION

HOSE TYPE	FITTING TYPE	MAX HOSE SIZE
2 WIRE BRAID & TEXTILE	MF2000 MULTIFIT; MF3000 OPF; MF3000 OPK	2"
3 WIRE (1 BRAID + 2 SPIRAL)	MF2000 MULTIFIT; MF2000 INTERLOCK PLUS; MF2000 SPIRALFIT	1 1/4"
4 WIRE SPIRALS	MF2000 MULTIFIT; MF3000 OPK	2"
4 WIRE SPIRALS	MF2000 INTERLOCK PLUS; MF2000 SPIRALFIT	1 1/4"
6 WIRE SPIRAL	MF2000 INTERLOCK PLUS;	1"

MV 240 L

FIELD SERVICE & MOBILE WORKSHOP
MOBILE VAN



KEY FEATURES

- Robust design
- Ergonomic micrometer
- High crimping speed
- Radial movement of the dies
- Cylinder protection

OPTIONAL



Maintenance Kit



Quick Change Gun



Aluminium Quick Change Gun

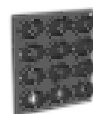

Die Storage Panel



Battery & Charger



Marking Dies



Die Sets for Brake & Air Conditioning Hoses



Front Die Storage



Ergonomic Micrometer

TECHNICAL SPECIFICATIONS

CRIMP RANGE

4 - 76 mm (0.157 - 2.992")

CRIMP FORCE

240 t

OPENING WITH DIES

+38 mm (+1.496")

COMPLETE OPENING

118 mm (4.646")

MASTER DIE LENGTH

100 mm (3.937")

STANDARD DIES

15, 18, 21, 24, 27, 30, 33, 36, 39, 42, 45, 48, 51, 57, 62, 66, 70

NOISE LEVEL

72 dB A

TECHNICAL FEATURES

Dimensions of power pack:
440 x 320 x 320 mm
(17 x 13 x 13")

MOTOR

2.0 kW

VOLTAGES

12 V

24 V

220/240 V, 3Ph, 50 Hz

380/415 V, 3Ph, 50 Hz

208/240 V, 3Ph, 60 Hz

380/415 V, 3Ph, 60 Hz

DIMENSIONS

320 x 360 x 350 mm
(13 x 13.5 x 14")

PACKAGING

800 x 600 x 830 mm
(31 x 24 x 33")

NET WEIGHT

130 kg (287 lb)

GROSS WEIGHT

180 kg (397 lb)

HOSE AND FITTINGS SELECTION

HOSE TYPE	FITTING TYPE	MAX HOSE SIZE
2 WIRE BRAID & TEXTILE	MF2000 MULTIFIT; MF3000 OPF; MF3000 OPK	2"
3 WIRE (1 BRAID + 2 SPIRAL)	MF2000 MULTIFIT; MF2000 INTERLOCK PLUS; MF2000 SPIRALFIT	1 1/4"
4 WIRE SPIRALS	MF2000 MULTIFIT; MF3000 OPK	2"
4 WIRE SPIRALS	MF2000 INTERLOCK PLUS; MF2000 SPIRALFIT	1 1/4"
6 WIRE SPIRAL	MF2000 INTERLOCK PLUS;	1"

MV 350

FIELD SERVICE & MOBILE / CONTAINER WORKSHOP
MOBILE VAN



KEY FEATURES

- Robust design
- Large opening
- High crimping force
- Ergonomic micrometer
- High crimping speed
- Radial movement of the dies
- Cylinder protection
- Remote head mounting option possible

TECHNICAL SPECIFICATIONS

CRIMP RANGE

4 - 130 mm (0.157 - 5.118")

CRIMP FORCE

350 t

OPENING WITH DIES

+54 mm (+2.125")

COMPLETE OPENING

180 mm (7.086")

MASTER DIE LENGTH

115 mm (4.528")

STANDARD DIES

15, 18, 21, 24, 27, 30, 33, 36, 39, 42, 45, 48, 51, 57, 62, 66, 70, 73, 76

NOISE LEVEL

<65 dB A

MOTOR

2.0 kW

VOLTAGES

12 V

24 V

220/240 V, 3Ph, 50 Hz

380/415 V, 3Ph, 50 Hz

208/240 V, 3Ph, 60 Hz

380/415 V, 3Ph, 60 Hz

DIMENSIONS

650 x 550 x 750 mm

(26 x 22 x 30")

PACKAGING

800 x 600 x 830 mm

(31 x 24 x 33")

NET WEIGHT

210 kg (463 lb)

GROSS WEIGHT

260 kg (573 lb)

SAFETY REMARK

Possible limitations in case of double elbow fittings

OPTIONAL



Maintenance Kit



Quick Change Gun



Aluminium Quick Change Gun

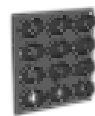

Die Storage Panel



Battery & Charger



Marking Dies



Die Sets for Brake & Air Conditioning Hoses



Front Die Storage

MV 350

FIELD SERVICE & MOBILE / CONTAINER WORKSHOP MOBILE VAN

HOSE AND FITTINGS SELECTION		
HOSE TYPE	FITTING TYPE	MAX HOSE SIZE
2 WIRE BRAID & TEXTILE	MF2000 MULTIFIT; MF3000 OPF; MF3000 OPK	3"
3 WIRE (1 BRAID + 2 SPIRAL)	MF2000 MULTIFIT; MF2000 INTERLOCK PLUS; MF2000 SPIRALFIT;	1 ¼"
4 WIRE SPIRALS	MF2000 MULTIFIT; MF2000 INTERLOCK PLUS; MF2000 SPIRALFIT; MF3000 OPK	2"
5 WIRE (4 SPIRAL + 1 BRAID)	MF2000 INTERLOCK PLUS	1 ¼"
7 WIRE (6 SPIRAL + 1 BRAID)	MF2000 INTERLOCK SUPER	1 ½"
6 WIRE SPIRAL	MF2000 INTERLOCK PLUS; MF2000 INTERLOCK SUPER; MF2000 SPIRALFIT	1 ½"

MS 140

ASSEMBLING FOR MASS PRODUCTION STAND TYPE CRIMP MACHINE, SCS SYSTEM



KEY FEATURES

- Safe Crimp System (SCS) control
- Large production capacity (small/medium bore)
- Low noise level
- Precise
- Robust
- Fast crimping
- Easy die set-up with ergonomic gun

OPTIONAL



Aluminium Quick Change Gun



Electrical Footswitch

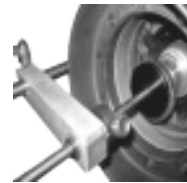

Mechanical Backstop



Mirror



Back View Camera

TECHNICAL SPECIFICATIONS

CRIMP RANGE

4 - 70 mm (0.157 - 2.756")

NOISE LEVEL

<69 dB A

CRIMP FORCE

140 t

MOTOR

5.5 kW

OPENING WITH DIES

+45 mm (+1.772")

VOLTAGES

220/240 V, 3Ph, 50 Hz

COMPLETE OPENING

125 mm (4.921")

380/415 V, 3Ph, 50 Hz

208/240 V, 3Ph, 60 Hz

MASTER DIE LENGTH

80 mm (3.150")

DIMENSIONS

890 x 810 x 1390 mm

STANDARD DIES

15, 18, 21, 24, 27, 30, 33,
36, 39, 42, 45, 48

(35 x 32 x 55")

PACKAGING

1120 x 1020 x 1770 mm

(44 x 40 x 70")

NET WEIGHT

675 kg (1488 lb)

HOSE AND FITTINGS SELECTION

HOSE TYPE	FITTING TYPE	MAX HOSE SIZE
2 WIRE BRAID & TEXTILE	MF2000 MULTIFIT; MF3000 OPF; MF3000 OPK	1 ¼"
3 WIRE (1 BRAID + 2 SPIRAL)	MF2000 MULTIFIT;	1 ¼"
4 WIRE SPIRALS	MF2000 MULTIFIT; MF3000 OPK	1 ¼"
3 WIRE (1 BRAID + 2 SPIRAL)	MF2000 INTERLOCK PLUS; MF2000 SPIRALFIT	1"
4 WIRE SPIRALS	MF2000 INTERLOCK PLUS; MF2000 SPIRALFIT	1"

MS 320

ASSEMBLING FOR MASS PRODUCTION STAND TYPE CRIMP MACHINE, SCS SYSTEM



KEY FEATURES

- High crimp force
- Large opening
- Safe Crimp System (SCS) control
- Wide family of dies for industrial hoses
- Robust structure
- Fast and ergonomic
- Low noise level
- Easy die-set up with ergonomic gun

STANDARD



Quick Change Gun



SCS Safe Crimp System



Electrical Footswitch

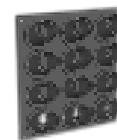

Die Storage



Mirror

TECHNICAL SPECIFICATIONS

CRIMP RANGE

4 - 130 mm (0.157 - 5.118")

MOTOR

5.5 kW / 7.5 kW (Fast Version)

CRIMP FORCE

320 t

VOLTAGES

220/240 V, 3Ph, 50 Hz

OPENING WITH DIES

+80 mm (+3.149")

380/415 V, 3Ph, 50 Hz

COMPLETE OPENING

207 mm (8.149")

208/240 V, 3Ph, 60 Hz

380/415 V, 3Ph, 60 Hz

MASTER DIE LENGTH

100 mm (3.937")

DIMENSIONS

1240 x 995 x 1615 mm

(49 x 39 x 64")

STANDARD DIES

15, 18, 21, 24, 27, 30, 33, 36, 39, 42, 45, 48, 51, 57, 62, 66, 70, 73, 76

PACKAGING

1400 x 1100 x 1960 mm

(55 x 43 x 77")

NOISE LEVEL

<65 dB A

NET WEIGHT

2000 kg (4409 lb)

GROSS WEIGHT

2300 kg (5071 lb)

OPTIONAL

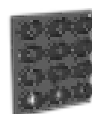

Die Storage Panel



Marking Dies



Back View Camera



Aluminium Quick Change Gun



Mechanical Backstop



Side Table & Pushing Panel



Die Sets for Brake & Air Conditioning Hoses



Automatic Central Greasing System

MS 320

ASSEMBLING FOR MASS PRODUCTION STAND TYPE CRIMP MACHINE, SCS SYSTEM

HOSE AND FITTINGS SELECTION

HOSE TYPE	FITTING TYPE	MAX HOSE SIZE
2 WIRE BRAID & TEXTILE	MF2000 MULTIFIT; MF3000 OPF; MF3000 OPK;	3"
3 WIRE (1 BRAID + 2 SPIRAL)	MF2000 MULTIFIT; MF2000 INTERLOCK PLUS; MF2000 SPIRALFIT;	1 ¼"
4 WIRE SPIRALS	MF2000 MULTIFIT; MF2000 INTERLOCK PLUS; MF2000 SPIRALFIT; MF3000 OPK	2"
5 WIRE (4 SPIRAL + 1 BRAID)	MF2000 INTERLOCK PLUS	1 ¼"
7 WIRE (6 SPIRAL + 1 BRAID)	MF2000 INTERLOCK SUPER	1 ½"
6 WIRE SPIRALS (ROCKMASTER/13 - GOLDENISO/35 XTRAFLEX - SHIELDMASTER/35 - DIAMONDSPIR)	MF2000 INTERLOCK PLUS; MF2000 SPIRALFIT	2"
8 WIRE SPIRALS	MF2000 INTERLOCK PLUS	1 ¼"

MS 480

ASSEMBLING FOR MASS PRODUCTION STAND TYPE CRIMP MACHINE, SCS SYSTEM



KEY FEATURES

- High crimp force
- Large opening
- Safe Crimp System (SCS) control
- Wide family of dies for industrial hoses
- Long master dies
- Robust
- Low noise level
- Easy die set-up with ergonomic gun

STANDARD



Quick Change Gun



SCS Safe Crimp System



Electrical Footswitch

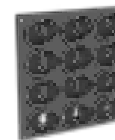

Die Storage



Mirror

TECHNICAL SPECIFICATIONS

CRIMP RANGE

4 - 160 mm (0.157 - 6.299")

MOTOR

5.5 kW

CRIMP FORCE

480 t

VOLTAGES

220/240 V, 3Ph, 50 Hz

OPENING WITH DIES

+85 mm (+3.346")

380/415 V, 3Ph, 50 Hz

COMPLETE OPENING

212 mm (8.346")

208/240 V, 3Ph, 60 Hz

DIMENSIONS

MASTER DIE LENGTH

125 mm (4.921")

1300 x 900 x 1700 mm
(51 x 35 x 67")

STANDARD DIES

15, 18, 21, 24, 27, 30, 33,
36, 39, 42, 45, 48, 51, 57,
62, 66, 70, 73, 76

PACKAGING

1400 x 1100 x 1960 mm
(55 x 43 x 77")

NOISE LEVEL

<65 dB A

NET WEIGHT

2200 kg (4850 lb)

GROSS WEIGHT

2430 kg (5357 lb)

OPTIONAL

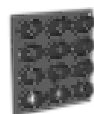

Die Storage Panel



Marking Dies



Back View Camera



Aluminium Quick
Change Gun



Mechanical
Backstop



Side Table & Pushing
Panel



Die Sets for Brake & Air
Conditioning Hoses



Automatic Central Greasing System

MS 480

ASSEMBLING FOR MASS PRODUCTION STAND TYPE CRIMP MACHINE, SCS SYSTEM

HOSE AND FITTINGS SELECTION

HOSE TYPE	FITTING TYPE	MAX HOSE SIZE
2 WIRE BRAID & TEXTILE	MF2000 MULTIFIT; MF3000 OPF; MF3000 OPK;	4"
3 WIRE (1 BRAID + 2 SPIRAL)	MF2000 MULTIFIT; MF2000 INTERLOCK PLUS; MF2000 SPIRALFIT;	1 ¼"
4 WIRE SPIRALS	MF2000 MULTIFIT; MF2000 INTERLOCK PLUS; MF2000 SPIRALFIT; MF3000 OPK	4"
5 WIRE (4 SPIRAL + 1 BRAID)	MF2000 INTERLOCK PLUS	1 ¼"
7 WIRE (6 SPIRAL + 1 BRAID)	MF2000 INTERLOCK SUPER	1 ½"
7 WIRE (6 SPIRAL + 1 BRAID)	MF2000 INTERLOCK PLUS	2"
6 WIRE SPIRALS	MF2000 INTERLOCK PLUS; MF2000 SPIRALFIT	3"
6 WIRE SPIRALS	MF2000 INTERLOCK SUPER; MF2000 SPIRALFIT-GX	2"
8 WIRE SPIRALS	MF2000 INTERLOCK SUPER	1 ½"

MS 800

ASSEMBLING FOR LARGE BORE HOSES STAND TYPE CRIMP MACHINE, SCS CONTROL



KEY FEATURES

- Designed for heavy duty large bore hydraulic hoses
- High power and speed
- Ergonomically designed for large bore hoses
- Safe Crimp System (SCS) for maximum reliability during the crimping process
- Large opening up to 8"
- Long master dies
- Very high crimping force

STANDARD



Electrical Footswitch



SCS Safe Crimp System



Hose Support

TECHNICAL SPECIFICATIONS

CRIMP RANGE

4 - 230 mm (0.157 - 9.055")

CRIMP FORCE

800 t

OPENING WITH DIES

+100 mm (+3.937")

COMPLETE OPENING

347 mm (13.661")

MASTER DIE LENGTH

180 mm (7.087")

NOISE LEVEL

< 70 dB A

MOTOR

7.5 kW

VOLTAGES

380/415 V, 3Ph, 50 Hz

DIMENSIONS

1400 x 1400 x 2060 mm

(55 x 55 x 81")

NET WEIGHT

4300 kg (9480 lb)

GROSS WEIGHT

5000 kg (11023 lb)

TECHNICAL FEATURES

- Machine platform equipped with rollers to support the hose at working height (1100 mm) in order to handle large bore hoses more easily
- Supplied as standard: Intermediate dies 250/130

OPTIONAL



Quick Change Gun



Die Storage Panel



Back View Camera

MS 800

ASSEMBLING FOR LARGE BORE HOSES STAND TYPE CRIMP MACHINE, SCS CONTROL

HOSE AND FITTINGS SELECTION

HOSE TYPE	FITTING TYPE	MAX HOSE SIZE
INDUSTRIAL TEXTILE HOSES	VARIOUS	8"
2 WIRE BRAID & TEXTILE	MF2000 MULTIFIT; MF3000 OPF; MF3000 OPK;	4"
3 WIRE (1 BRAID + 2 SPIRAL)	MF2000 MULTIFIT; MF2000 INTERLOCK PLUS; MF2000 SPIRALFIT;	1 ¼"
4 WIRE SPIRALS	MF2000 MULTIFIT; MF2000 INTERLOCK PLUS; MF2000 SPIRALFIT; MF3000 OPK	4"
5 WIRE (4 SPIRAL + 1 BRAID)	MF2000 INTERLOCK PLUS	1 ¼"
7 WIRE (6 SPIRAL + 1 BRAID)	MF2000 INTERLOCK SUPER	3"
6/8 WIRE SPIRALS	MF2000 INTERLOCK PLUS; MF2000 SPIRALFIT; MF2000 INTERLOCK SUPER	3"

MS 320 OPEN HEAD

XXL WORKSHOP



KEY FEATURES

- Unique on market
- Lateral opening
- No limit on end connection diameter
- Easy to use
- Separated power pack
- Integrated safety system

TECHNICAL SPECIFICATIONS

CAPACITY*

Industrial: 6"

CRIMP RANGE

4 - 230 mm (0.157 - 9.055")

CRIMP FORCE

320 t

OPENING WITH DIES

+55 mm (+2.165")

COMPLETE OPENING

260 mm (10.236")

LATERAL OPENING

247 mm (9.724")

MASTER DIE LENGTH

125 mm (4.921")

MOTOR

5.5 kW

VOLTAGES

230 V, 3 Ph

400 V, 3 Ph

MACHINE DIMENSIONS

1265 x 680 x 1800 mm

(50 x 27 x 71")

POWER PACK DIMENSIONS

890 x 800 x 1050 mm

(35 x 31 x 41")

MACHINE WEIGHT

1700 kg (3748 lb)

POWER PACK WEIGHT

400 kg (882 lb)

TECHNICAL FEATURES

-Die sizes available upon request

STANDARD



Electrical Footswitch

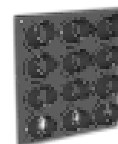

Die Storage

*Indicative capacities depending on hose and fitting type

KEY FEATURES

- High crimp force (450 tonnes)
- Large opening
- Wide family of dies for industrial hoses
- Long master dies
- Robust - designed for harsh environments
- Low noise level
- Easy die set-up with ergonomic gun
- Metallic guard for the set stop
- Separated crimping head allowing flexible workshop arrangements



TECHNICAL SPECIFICATIONS

CAPACITY *

Industrial: 4" & 6"

CRIMP RANGE

4 - 180 mm (0.157 - 7.087")

CRIMP FORCE

450 t

OPENING WITH DIES

+70 mm (+2.755")

COMPLETE OPENING

230 mm (9.055")

MASTER DIE LENGTH

125 mm (4.921")

STANDARD DIES

15, 18, 21, 24, 27, 30, 33, 36, 39, 42, 45, 48, 51, 57, 62, 66, 70, 73, 76;
Extra die sets: up to 180 mm;
Die sizes available on request

MOTOR

5.5 kW

VOLTAGES

220/240 V, 3Ph, 50 Hz

380/415 V, 3Ph, 50 Hz

208/240 V, 3Ph, 60 Hz

380/415 V, 3Ph, 60 Hz

DIMENSIONS

830 x 775 x 1450 mm

(33 x 31 x 57")

PACKAGING

1120 x 1020 x 1770 mm

(44 x 40 x 70")

NET WEIGHT

450 kg (992 lb)

OPTIONAL

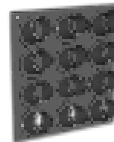

Die Storage Panel



Die Storage Table



Quick Change Gun



Marking Dies



Aluminium Quick Change Gun



Die Sets for Brake & Air Conditioning Hoses



Electrical Footswitch

*Indicative capacities depending on hose and fitting type

MS 550/MS 550-16

XXL WORKSHOP



KEY FEATURES

- Very large opening
- Fixed bottom die
- Long dies available
- High crimping force
- Symmetric machine
- Low working height
- Ergonomic
- Safe Crimp System (SCS)
- Step crimping capability with SCS

STANDARD



SCS Safe Crimp System



Die Storage

OPTIONAL



Back View Camera

TECHNICAL SPECIFICATIONS

	MS 550	MS 550-16
CAPACITY*	Industrial: 12"	Industrial: 16"
CRIMP FORCE	550 t	550 t
COMPLETE OPENING	490 mm (19.291")	660 mm (25.984")
OPENING WITH DIES	+130 mm (+5.118")	+160 mm (6.299")
MASTER DIE LENGTH	200 mm (7.874")	200 mm (7.874")
MOTOR	5.5 kW	5.5 kW
VOLTAGES	230 V, 3 Ph 400 V, 4 Ph	230 V, 3 Ph 400 V, 4 Ph
MACHINE DIMENSIONS	1300 x 1050 x 2230 mm (35 x 41 x 88")	1450 x 1100 x 2300 mm (57 x 43 x 91")
POWER PACK DIMENSIONS	800 x 790 x 1650 mm (31 x 31 x 65")	800 x 790 x 1650 mm (31 x 31 x 65")
MACHINE WEIGHT	4000 kg (8818 lb)	4300 kg (9480 lb)
POWER PACK WEIGHT	500 kg (1102 lb)	500 kg (1102 lb)
TECHNICAL FEATURES	Die sizes available upon request	

*Indicative capacities depending on hose and fitting type

ACCESSORIES AND TOOLS

SAFE CRIMP (SC) SMART CONTROL PANEL

A basic smart control panel, which includes maintenance functions essential for keeping the machine in good condition.

Maintenance functions include:

- **2 Counters:** 1 daily counter and 1 machine cycle counter
- **3 LED Indicator Lights:** 1 for daily maintenance, 1 for advanced maintenance and 1 for expert maintenance
- **Semi-automatic function:** The semi-automatic opening is ideal for serial assemblies as it can be adjusted specifically to allow the fitting to pass through the dies with minimal clearance, saving energy by reducing the cycle time.
- **Integrated Bluetooth:** Receive crimping data from the Manuli crimping app to reduce the risk of operator error



SAFE CRIMP ELECTRICAL PANEL (SCE)

A modern touch screen with electronic buttons, which includes maintenance functions essential for keeping the machine in good condition.

Maintenance functions include:

- **Functions of the Safe Crimp Panel**
- **Electronic micrometer** with automatic die selection and the ability to save up to 25 configurations
- **Integrated Bluetooth:** Receive crimping data from the Manuli crimping app to reduce the risk of operator error
- **Optional calliper control:** Integrated vernier caliper connected to the machine which allows automatic correction of crimping diameters based on measured values



ACCESSORIES AND TOOLS

SAFE CRIMP SYSTEM



Benefits of Safe Crimp System control for hose assembly activity:

- Friendly and easy setting of crimping parameters including:
 - ✓ Pre-set of crimp Ø calibration to compensate ferrule elastic rebound
 - ✓ Reminder of dies to be used
 - ✓ Easy automatic opening setting
- Storage of recurrent and customised crimp recipes: favourite crimp assemblies:
 - ✓ Short cuts for faster setting
 - ✓ No crimp Ø re-adjusting
 - ✓ Possibility to download your customised recipes by USB port and save on separate computer (CSV file)
- Production counter for batch quantity control:
 - ✓ Quality monitoring by: Automatic crimp Ø check (Only available on 7" screen)
 - ✓ Continuous crimp pressure measurement (Option on 4.5" screen)
 - ✓ Crimping pressure and count control for mistake proofing assembly (Option 4.5" screen)
- Operator identification (Log in / log out)
- Maintenance Warnings

MTB 2000 L

TEST BENCH, PROOF PRESSURE & CERTIFY STAND TYPE MACHINE

KEY FEATURES

- Easy to use and robust
- Safe: Steel Compartment, polycarbonate transparent window and metal mesh
- Large testing area for up to 6 hoses
- Pallet loading with a forklift
- Variable pressure up to 2000 bar



STANDARD

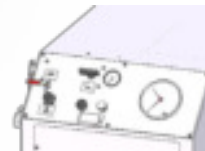

Power Unit M



Power Unit E

TECHNICAL SPECIFICATIONS

INDICATIVE CAPACITY

1200 mm (48")

HOSE CONNECTION

6 maximum

AIR CONSUMPTION

100 NI/min

OPENING/CLOSING TIME

10-14 seconds

MAX PRESSURE

2000 bar (29000 psi)

INNER TANK CAPACITY

1700 x 790 x 200 mm
(67 x 31 x 8")

DIMENSIONS (PANEL)

700 x 1200 x 1220 mm
(28 x 47 x 48")

PACKAGING (TANK)

1600 x 1200 x 1280 mm
(63 x 47 x 50")

PACKAGING (PANEL)

1000 x 1200 x 1280 mm
(39 x 47 x 50")

WEIGHT

430 kg (948 lb)

NET WEIGHT

500 kg (1102 lb)

TECHNICAL FEATURES

-Minimum compressed air
input 8.5 bar (123 psi)

FEATURES AND OPTIONS

DISPLAY FEATURES

- M** Gauge measurement display
- E** Numerical measurement colour display with ethernet port for mirror link connection with computer

FURTHER OPTIONS

- Autonomous filling pump
- Air blowing system for both models
- Second tank available on all models

MTB 2000 XL

TEST BENCH, PROOF PRESSURE & CERTIFY
STAND TYPE MACHINE

KEY FEATURES

- Easy to use and robust
- Safe: Steel Compartment, polycarbonate transparent window and metal mesh
- Large testing area for up to 6 hoses
- Pallet loading with a forklift
- Variable pressure up to 2000 bar
- Print test data directly to USB drive or printer
- ISD model supplied with colour printer



Model shown XL ISD

TECHNICAL SPECIFICATIONS

INDICATIVE CAPACITY

1200 mm (48")

HOSE CONNECTION

6 maximum

AIR CONSUMPTION

100 NI/min

OPENING/CLOSING TIME

10-14 seconds

MAX PRESSURE

2000 bar (29000 psi)

INNER TANK CAPACITY

1400 x 900 x 600 mm
(55 x 35 x 24")

DIMENSIONS (PANEL)

700 x 1200 x 1220 mm
(28 x 47 x 48")

PACKAGING (TANK)

1600 x 1200 x 1280 mm
(63 x 47 x 50")

PACKAGING (PANEL)

1000 x 1200 x 1280 mm
(39 x 47 x 50")

WEIGHT

600 kg (1323 lb)

NET WEIGHT

500 kg (1102 lb)

TECHNICAL FEATURES

-Minimum compressed air input 8.5 bar (123 psi)
-Minimum test pressure 250 bar (3626 psi), with low pressure option 50 bar (725 psi) (only for XL ISD)

FEATURES AND OPTIONS

STANDARD OPTIONS

XL ISD:

- Light included
- Touch screen panel
- Printer

XL E:

- LED Light included
- Numerical measurement colour display with ethernet port for mirror link connection with computer

FURTHER OPTIONS

- Autonomous filling pump
- Air blowing system for both models
- Second tank available on all models
- Low pressure pump (50 bar - 300 bar) available on ISD model

DESCRIPTION	N°	CRIMP RANGE
DIE SET N. 06 - LENGTH 56 MM	6	06-08
DIE SET N. 08 - LENGTH 56 MM	8	08-10
DIE SET N. 10 - LENGTH 56 MM	10	10-12
DIE SET N. 12 - LENGTH 56 MM	12	12-15
DIE SET N. 15 - LENGTH 56 MM	15	15-18
DIE SET N. 18 - LENGTH 56 MM	18	18-21
DIE SET N. 21 - LENGTH 56 MM	21	21-24
DIE SET N. 24 - LENGTH 56 MM	24	24-27
DIE SET N. 27 - LENGTH 56 MM	27	27-30
DIE SET N. 30 - LENGTH 56 MM	30	30-43
KIT 6 DIES MHP80 (N.15 TO N.30)	-	-

MHP 110

PG.552

DESCRIPTION	N°	CRIMP RANGE
DIE SET N. 06 - LENGTH 56 MM	6	06-08
DIE SET N. 08 - LENGTH 56 MM	8	08-10
DIE SET N. 10 - LENGTH 56 MM	10	10-12
DIE SET N. 12 - LENGTH 56 MM	12	12-15
<i>DIE SET N. 15 - LENGTH 56 MM</i>	15	15-18
<i>DIE SET N. 18 - LENGTH 56 MM</i>	18	18-21
<i>DIE SET N. 21 - LENGTH 56 MM</i>	21	21-24
<i>DIE SET N. 24 - LENGTH 56 MM</i>	24	24-27
<i>DIE SET N. 27 - LENGTH 56 MM</i>	27	27-30
<i>DIE SET N. 30 - LENGTH 56 MM</i>	30	30-39
<i>KIT 6 DIES MHP110 (N.15 TO N.30)</i>	-	-

DESCRIPTION	N°	CRIMP RANGE
DIE SET N. 4 - LENGTH 56 MM	4	04-05
DIE SET N. 6 - LENGTH 56 MM	6	06-07
DIE SET N. 7 - LENGTH 56 MM	7	07-08
DIE SET N. 8 - LENGTH 56 MM	8	08-10
DIE SET N. 9 - LENGTH 56 MM	9	09-10
DIE SET N. 10 - LENGTH 56 MM	10	10-12
DIE SET N. 12 - LENGTH 56 MM	12	12-15
DIE SET N. 14 - LENGTH 56 MM	14	14-15
DIE SET N. 15 - LENGTH 56 MM	15	15-18
DIE SET N. 17 - LENGTH 56 MM	17	17-18
DIE SET N. 18 - LENGTH 56 MM	18	18-21
DIE SET N. 20 - LENGTH 56 MM	20	20-21
DIE SET N. 21 - LENGTH 56 MM	21	21-24
DIE SET N. 24 - LENGTH 56 MM	24	24-27
DIE SET N. 27 - LENGTH 56 MM	27	27-30
DIE SET N. 30 - LENGTH 56 MM	30	30-33
DIE SET N. 33 - LENGTH 70 MM	33	33-36
DIE SET N. 36 - LENGTH 75 MM	36	36-39
DIE SET N. 39 - LENGTH 70 MM	39	39-42
DIE SET N. 42 - LENGTH 70 MM	42	42-45
DIE SET N. 45 - LENGTH 70 MM	45	45-48
DIE SET N. 48 - LENGTH 70 MM	48	48-51
DIE SET N. 51 - LENGTH 75 MM	51	51-57
KIT 4 DIES MHP137 (N.15 TO N.33)	-	-
KIT 5 DIES MHP137 (N.15 TO N.39)	-	-
KIT 6 DIES MHP137 (N.15 TO N.39)	-	-
KIT 7 DIES MHP137 (N.15 TO N.39)	-	-
KIT 9 DIES MHP137 (N.15 TO N.45)	-	-
KIT 9 DIES MHP137 (N.15 TO N.48)	-	-
KIT 10 DIES MHP137 (N.15 TO N.48)	-	-
KIT 13 DIES HCRIMP137 (N.15 TO N.51)	-	-

DESCRIPTION	N°	CRIMP RANGE
DIE SET N. 4 - LENGTH 56 MM	4	04-05
DIE SET N. 6 - LENGTH 56 MM	6	06-07
DIE SET N. 7 - LENGTH 56 MM	7	07-08
DIE SET N. 9 - LENGTH 56 MM	9	09-10
DIE SET N. 8 - LENGTH 56 MM	8	08-10
DIE SET N. 10 - LENGTH 56 MM	10	10-12
DIE SET N. 12 - LENGTH 56 MM	12	12-15
DIE SET N. 14 - LENGTH 56 MM	14	14-15
DIE SET N. 15 - LENGTH 56 MM	15	15-18
DIE SET N. 17 - LENGTH 56 MM	17	17-18
DIE SET N. 18 - LENGTH 56 MM	18	18-21
DIE SET N. 20 - LENGTH 56 MM	20	20-21
DIE SET N. 21 - LENGTH 56 MM	21	21-24
DIE SET N. 24 - LENGTH 56 MM	24	24-27
DIE SET N. 27 - LENGTH 56 MM	27	27-30
DIE SET N. 30 - LENGTH 56 MM	30	30-33
DIE SET N. 33 - LENGTH 70 MM	33	33-36
DIE SET N. 36 - LENGTH 75 MM	36	36-39
DIE SET N. 39 - LENGTH 70 MM	39	39-42
DIE SET N. 42 - LENGTH 70 MM	42	42-45
DIE SET N. 45 - LENGTH 70 MM	45	45-48
DIE SET N. 48 - LENGTH 70 MM	48	48-51
DIE SET N. 51 - LENGTH 75 MM	51	51-57
KIT 4 DIES MRB137EVOR (N.15 TO N.33)	-	-
KIT 5 DIES MRB137EVOR (N.15 TO N.39)	-	-
KIT 6 DIES MRB137EVOR (N.15 TO N.39)	-	-
KIT 7 DIES MRB137EVOR (N.15 TO N.39)	-	-
KIT 9 DIES MRB137EVOR (N.15 TO N.45)	-	-
KIT 9 DIES MRB137EVOR (N.15 TO N.48)	-	-
KIT 10 DIES MRB137EVOR (N.15 TO N.48)	-	-
KIT 13 DIES MRB137EVOR (N.15 TO N.51)	-	-

DESCRIPTION	N°	CRIMP RANGE
DIE SET N. 4 - LENGTH 56 MM	4	04-05
DIE SET N. 6 - LENGTH 56 MM	6	06-07
DIE SET N. 7 - LENGTH 56 MM	7	07-08
DIE SET N. 9 - LENGTH 56 MM	9	09-10
DIE SET N. 8 - LENGTH 56 MM	8	08-10
DIE SET N. 10 - LENGTH 56 MM	10	10-12
DIE SET N. 12 - LENGTH 56 MM	12	12-15
DIE SET N. 14 - LENGTH 56 MM	14	14-15
DIE SET N. 15 - LENGTH 56 MM	15	15-18
DIE SET N. 17 - LENGTH 56 MM	17	17-18
DIE SET N. 18 - LENGTH 56 MM	18	18-21
DIE SET N. 20 - LENGTH 56 MM	20	20-21
DIE SET N. 21 - LENGTH 56 MM	21	21-24
DIE SET N. 24 - LENGTH 56 MM	24	24-27
DIE SET N. 27 - LENGTH 56 MM	27	27-30
DIE SET N. 30 - LENGTH 56 MM	30	30-33
DIE SET N. 33 - LENGTH 70 MM	33	33-36
DIE SET N. 36 - LENGTH 75 MM	36	36-39
DIE SET N. 39 - LENGTH 70 MM	39	39-42
DIE SET N. 42 - LENGTH 70 MM	42	42-45
DIE SET N. 45 - LENGTH 70 MM	45	45-48
DIE SET N. 48 - LENGTH 70 MM	48	48-51
DIE SET N. 51 - LENGTH 75 MM	51	51-57
KIT 4 DIES MB137EVO (N.15 TO N.33)	-	-
KIT 5 DIES MB137EVO (N.15 TO N.39)	-	-
KIT 6 DIES MB137EVO (N.15 TO N.39)	-	-
KIT 7 DIES MB137EVO (N.15 TO N.39)	-	-
KIT 9 DIES MB137EVO (N.15 TO N.45)	-	-
KIT 9 DIES MB137EVO (N.15 TO N.48)	-	-
KIT 10 DIES MB137EVO (N.15 TO N.48)	-	-
KIT 13 DIES MB137EVO (N.15 TO N.51)	-	-

DESCRIPTION	N°	CRIMP RANGE
DIE SET N. 4 - LENGTH 56 MM	4	04-05
DIE SET N. 6 - LENGTH 56 MM	6	06-08
DIE SET N. 7 - LENGTH 56 MM	7	07-08
DIE SET N. 8 - LENGTH 56 MM	8	08-09
DIE SET N. 9 - LENGTH 56 MM	9	09-10
DIE SET N. 10 - LENGTH 56 MM	10	10-12
DIE SET N. 12 - LENGTH 56 MM	12	12-15
DIE SET N. 14 - LENGTH 56 MM	14	14-15
DIE SET N. 15 - LENGTH 56 MM	15	15-18
DIE SET N. 17 - LENGTH 56 MM	17	17-18
DIE SET N. 18 - LENGTH 56 MM	18	18-21
DIE SET N. 20 - LENGTH 56 MM	20	20-21
DIE SET N. 21 - LENGTH 56 MM	21	21-24
DIE SET N. 24 - LENGTH 70 MM	24	24-27
DIE SET N. 27 - LENGTH 90 MM	27	27-30
DIE SET N. 30 - LENGTH 90 MM	30	30-33
DIE SET N. 33 - LENGTH 90 MM	33	33-36
DIE SET N. 36 - LENGTH 90 MM	36	36-39
DIE SET N. 39 - LENGTH 90 MM	39	39-42
DIE SET N. 42 - LENGTH 90 MM	42	42-45
DIE SET N. 45 - LENGTH 100 MM	45	45-48
DIE SET N. 48 - LENGTH 100 MM	48	48-51
DIE SET N. 51 - LENGTH 100 MM	51	51-57
DIE SET N. 54 - LENGTH 110 MM	54	54-57
DIE SET N. 57 - LENGTH 100 MM	57	57-62
DIE SET N. 60 - LENGTH 100 MM	60	60-62
DIE SET N. 62 - LENGTH 110 MM	62	62-66
DIE SET N. 66 - LENGTH 100 MM	66	66-70
DIE SET N. 70 - LENGTH 100 MM	70	70-72
DIE SET N. 72 - LENGTH 100 MM	72	72-80
KIT 9 DIES MB240EVO (N.15 TO N.51)	-	-
KIT 11 DIES MB240EVO (N.15 TO N.66)	-	-
KIT 12 DIES MB240EVO (N.15 TO N.66)	-	-
KIT 17 DIES MB240EVO (N.15 TO N.70)	-	-

DESCRIPTION	N°	CRIMP RANGE
DIE SET N. 4 - LENGTH 56 MM	4	04-05
DIE SET N. 6 - LENGTH 56 MM	6	06-08
DIE SET N. 7 - LENGTH 56 MM	7	07-08
DIE SET N. 8 - LENGTH 56 MM	8	08-09
DIE SET N. 9 - LENGTH 56 MM	9	09-10
DIE SET N. 10 - LENGTH 56 MM	10	10-12
DIE SET N. 12 - LENGTH 56 MM	12	12-15
DIE SET N. 14 - LENGTH 56 MM	14	14-15
DIE SET N. 15 - LENGTH 56 MM	15	15-18
DIE SET N. 17 - LENGTH 56 MM	17	17-18
DIE SET N. 18 - LENGTH 56 MM	18	18-21
DIE SET N. 20 - LENGTH 56 MM	20	20-21
DIE SET N. 21 - LENGTH 56 MM	21	21-24
DIE SET N. 24 - LENGTH 70 MM	24	24-27
DIE SET N. 27 - LENGTH 90 MM	27	27-30
DIE SET N. 30 - LENGTH 90 MM	30	30-33
DIE SET N. 33 - LENGTH 90 MM	33	33-36
DIE SET N. 36 - LENGTH 90 MM	36	36-39
DIE SET N. 39 - LENGTH 90 MM	39	39-42
DIE SET N. 42 - LENGTH 90 MM	42	42-45
DIE SET N. 45 - LENGTH 100 MM	45	45-48
DIE SET N. 48 - LENGTH 100 MM	48	48-51
DIE SET N. 51 - LENGTH 110 MM	51	51-57
DIE SET N. 54 - LENGTH 110 MM	54	54-57
DIE SET N. 57 - LENGTH 110 MM	57	57-62
DIE SET N. 60 - LENGTH 110 MM	60	60-62
DIE SET N. 62 - LENGTH 125 MM	62	62-66
DIE SET N. 66 - LENGTH 110 MM	66	66-70
DIE SET N. 66* - LENGTH 125 MM	66*	66-70
DIE SET N. 70 - LENGTH 100 MM	70	70-72
DIE SET N. 70* - LENGTH 125 MM	70*	70-72
DIE SET N. 72 - LENGTH 100 MM	72	72-73
DIE SET N. 73 - LENGTH 125 MM	73	73-76
DIE SET N. 75 - LENGTH 125 MM	75	75-76
DIE SET N. 76 - LENGTH 125 MM	76	76-86
DIE SET N. 80 - LENGTH 125 MM	80	80-86
DIE SET N. 86 - LENGTH 125 MM	86	86-90
DIE SET N. 90 - LENGTH 125 MM	90	90-95
DIE SET N. 95 - LENGTH 125 MM	95	95-105
DIE SET N. 99 - LENGTH 125 MM	99	99-109
DIE SET N. 112 - LENGTH 125 MM	112	112-117
DIE SET N. 117 - LENGTH 125 MM	117	117-122
DIE SET N. 122 - LENGTH 125 MM	122	122-127
KIT 13 DIES MB350EVO/L (N.15 TO N.73)	-	-
KIT 19 DIES MB350EVO/L (N.15 TO N.76)	-	-

DESCRIPTION	N°	CRIMP RANGE
DIE SET N. 4 - LENGTH 56 MM	4	04-05
DIE SET N. 6 - LENGTH 56 MM	6	06-08
DIE SET N. 7 - LENGTH 56 MM	7	07-08
DIE SET N. 8 - LENGTH 56 MM	8	08-09
DIE SET N. 10 - LENGTH 56 MM	10	10-12
DIE SET N. 12 - LENGTH 56 MM	12	12-15
DIE SET N. 15 - LENGTH 56 MM	15	15-18
DIE SET N. 17 - LENGTH 56 MM	17	17-18
DIE SET N. 18 - LENGTH 56 MM	18	18-21
DIE SET N. 20 - LENGTH 56 MM	20	20-21
DIE SET N. 21 - LENGTH 56 MM	21	21-24
DIE SET N. 24 - LENGTH 70 MM	24	24-27
DIE SET N. 27 - LENGTH 90 MM	27	27-30
DIE SET N. 30 - LENGTH 90 MM	30	30-33
DIE SET N. 33 - LENGTH 90 MM	33	33-36
DIE SET N. 36 - LENGTH 90 MM	36	36-39
DIE SET N. 39 - LENGTH 90 MM	39	39-42
DIE SET N. 42 - LENGTH 90 MM	42	42-45
DIE SET N. 45 - LENGTH 100 MM	45	45-48
DIE SET N. 48 - LENGTH 100 MM	48	48-51
DIE SET N. 51 - LENGTH 110 MM	51	51-57
DIE SET N. 54 - LENGTH 110 MM	54	54-57
DIE SET N. 57 - LENGTH 110 MM	57	57-62
DIE SET N. 60 - LENGTH 110 MM	60	60-62
DIE SET N. 62 - LENGTH 110 MM	62	60-62
DIE SET N. 62* - LENGTH 125 MM	62*	62-66
DIE SET N. 66 - LENGTH 110 MM	66	66-70
DIE SET N. 66* - LENGTH 125 MM	66*	66-70
DIE SET N. 70 - LENGTH 100 MM	70	70-72
DIE SET N. 70* - LENGTH 125 MM	70*	70-72
DIE SET N. 73 - LENGTH 125 MM	73	73-76
DIE SET N. 75 - LENGTH 125 MM	75	75-76
DIE SET N. 76 - LENGTH 125 MM	76	76-86
DIE SET N. 76* - LENGTH 135 MM	76*	76-86
DIE SET N. 80 - LENGTH 125 MM	80	80-82
DIE SET N. 82 - LENGTH 135 MM	82	82-90
DIE SET N. 86 - LENGTH 125 MM	86	86-90
DIE SET N. 86* - LENGTH 150 MM (FOR DIAMONDSPIR 2½")	86*	86-90
DIE SET N. 90 - LENGTH 125 MM	90	90-95
DIE SET N. 95 - LENGTH 125 MM	95	95-105
DIE SET N. 95* - LENGTH 150 MM (FOR DIAMONDSPIR 2½")	95*	95-105
KIT 13 DIE SET GOLDENCRIMP420EVO (15 TO 73)	-	-
KIT 19 DIE SET GOLDENCRIMP420EVO (15 TO 76)	-	-

DESCRIPTION	N°	CRIMP RANGE
DIE SET N. 4 - LENGTH 56 MM	4	04-05
DIE SET N. 6 - LENGTH 56 MM	6	06-08
DIE SET N. 7 - LENGTH 56 MM	7	07-08
DIE SET N. 8 - LENGTH 56 MM	8	08-09
DIE SET N. 10 - LENGTH 56 MM	10	10-12
DIE SET N. 12 - LENGTH 56 MM	12	12-15
DIE SET N. 15 - LENGTH 56 MM	15	15-18
DIE SET N. 17 - LENGTH 56 MM	17	17-18
DIE SET N. 18 - LENGTH 56 MM	18	18-21
DIE SET N. 20 - LENGTH 56 MM	20	20-21
DIE SET N. 21 - LENGTH 56 MM	21	21-24
DIE SET N. 24 - LENGTH 70 MM	24	24-27
DIE SET N. 27 - LENGTH 90 MM	27	27-30
DIE SET N. 30 - LENGTH 90 MM	30	30-33
DIE SET N. 33 - LENGTH 90 MM	33	33-36
DIE SET N. 36 - LENGTH 90 MM	36	36-39
DIE SET N. 39 - LENGTH 90 MM	39	39-42
DIE SET N. 42 - LENGTH 90 MM	42	42-45
DIE SET N. 45 - LENGTH 100 MM	45	45-48
DIE SET N. 48 - LENGTH 100 MM	48	48-51
DIE SET N. 51 - LENGTH 110 MM	51	51-57
DIE SET N. 54 - LENGTH 110 MM	54	54-57
DIE SET N. 57 - LENGTH 110 MM	57	57-62
DIE SET N. 60 - LENGTH 110 MM	60	60-62
DIE SET N. 62 - LENGTH 110 MM	62	62-66
DIE SET N. 62* - LENGTH 125 MM	62*	62-66
DIE SET N. 66 - LENGTH 110 MM	66	66-70
DIE SET N. 66* - LENGTH 125 MM	66*	66-70
DIE SET N. 70 - LENGTH 100 MM	70	70-72
DIE SET N. 70* - LENGTH 125 MM	70*	70-72
DIE SET N. 73 - LENGTH 125-28 MM, REINFORCED PIN	73	73-76
DIE SET N. 76 - LENGTH 125 MM	76	76-86
DIE SET N. 76* - LENGTH 135 MM	76*	76-86
DIE SET N. 80 - LENGTH 125 MM	80	80-82
DIE SET N. 82 - LENGTH 135 MM	82	82-90
DIE SET N. 86* - LENGTH 150 MM (FOR DIAMONDSPIR 2½")	86*	86-90
DIE SET N. 90 - LENGTH 125 MM	90	90-95
DIE SET N. 95 - LENGTH 150 MM (FOR DIAMONDSPIR 2½")	95*	95-105
DIE SET N. 99 - LENGTH 125 MM	99	95-105
DIE SET N. 105 - LENGTH 150 MM	105	99-109
DIE SET N. 112 - LENGTH 150 MM	112	112-122
DIE SET N. 117 - LENGTH 110 MM	117	117-127
DIE SET N. 122 - LENGTH 130 MM, REINFORCED PIN	122	122-130
KIT 13 DIE SET GOLDENCRIMP450EVO (15 TO 73)	-	-
KIT 19 DIE SET GOLDENCRIMP450EVO (15 TO 76)	-	-

DESCRIPTION	N°	CRIMP RANGE
DIE SET N. 4 - LENGTH 56 MM	4	04-05
DIE SET N. 6 - LENGTH 56 MM	6	06-08
DIE SET N. 7 - LENGTH 56 MM	7	07-08
DIE SET N. 8 - LENGTH 56 MM	8	08-10
DIE SET N. 9 - LENGTH 56 MM	9	09-10
DIE SET N. 10 - LENGTH 56 MM	10	10-12
DIE SET N. 12 - LENGTH 56 MM	12	12-15
DIE SET N. 14 - LENGTH 56 MM	14	14-15
DIE SET N. 15 - LENGTH 56 MM	15	15-18
DIE SET N. 17 - LENGTH 56 MM	17	17-18
DIE SET N. 18 - LENGTH 56 MM	18	18-21
DIE SET N. 20 - LENGTH 56 MM	20	20-21
DIE SET N. 21 - LENGTH 56 MM	21	21-24
DIE SET N. 24 - LENGTH 56 MM	24	24-27
DIE SET N. 27 - LENGTH 56 MM	27	27-30
DIE SET N. 30 - LENGTH 56 MM	30	30-33
DIE SET N. 33 - LENGTH 70 MM	33	33-36
DIE SET N. 36 - LENGTH 75 MM	36	36-39
DIE SET N. 39 - LENGTH 70 MM	39	39-42
DIE SET N. 42 - LENGTH 70 MM	42	42-45
DIE SET N. 45 - LENGTH 70 MM	45	45-48
DIE SET N. 48 - LENGTH 70 MM	48	48-51
DIE SET N. 51 - LENGTH 75 MM	51	51-57
KIT 4 DIES MVB137EVOR (N.15 TO N.33)	-	-
KIT 5 DIES MVB137EVOR (N.15 TO N.39)	-	-
KIT 6 DIES MVB137EVOR (N.15 TO N.39)	-	-
KIT 7 DIES MVB137EVOR (N.15 TO N.39)	-	-
KIT 9 DIES MVB137EVOR (N.15 TO N.45)	-	-
KIT 9 DIES MVB137EVOR (N.15 TO N.48)	-	-
KIT 10 DIES MVB137EVOR (N.15 TO N.48)	-	-
KIT 13 DIES MVB137EVOR (N.15 TO N.51)	-	-

DESCRIPTION	N°	CRIMP RANGE
DIE SET N. 4 - LENGTH 56 MM	4	04-05
DIE SET N. 6 - LENGTH 56 MM	6	06-08
DIE SET N. 8 - LENGTH 56 MM	8	08-10
DIE SET N. 10 - LENGTH 56 MM	10	10-12
DIE SET N. 12 - LENGTH 56 MM	12	12-15
DIE SET N. 15 - LENGTH 56 MM	15	15-18
DIE SET N. 17 - LENGTH 56 MM	17	17-18
DIE SET N. 18 - LENGTH 56 MM	18	18-21
DIE SET N. 20 - LENGTH 56 MM	20	20-21
DIE SET N. 21 - LENGTH 56 MM	21	21-24
DIE SET N. 24 - LENGTH 56 MM	24	24-27
DIE SET N. 27 - LENGTH 56 MM	27	27-30
DIE SET N. 30 - LENGTH 56 MM	30	30-33
DIE SET N. 33 - LENGTH 70 MM	33	33-36
DIE SET N. 36 - LENGTH 75 MM	36	36-39
DIE SET N. 39 - LENGTH 70 MM	39	39-42
DIE SET N. 42 - LENGTH 70 MM	42	42-45
DIE SET N. 45 - LENGTH 70 MM	45	45-48
DIE SET N. 48 - LENGTH 70 MM	48	48-51
DIE SET N. 51 - LENGTH 75 MM	51	51-57
KIT 4 DIES MV137L (N.15 TO N.33)	-	-
KIT 5 DIES MV137L (N.15 TO N.39)	-	-
KIT 6 DIES MV137L (N.15 TO N.39)	-	-
KIT 7 DIES MV137L (N.15 TO N.39)	-	-
KIT 9 DIES MV137L (N.15 TO N.45)	-	-
KIT 9 DIES MV137L (N.15 TO N.48)	-	-
KIT 10 DIES MV137L (N.15 TO N.48)	-	-
KIT 13 DIES MV137L (N.15 TO N.51)	-	-

DESCRIPTION	N°	CRIMP RANGE
DIE SET N. 4 - LENGTH 56 MM	4	04-05
DIE SET N. 6 - LENGTH 56 MM	6	06-08
DIE SET N. 7 - LENGTH 56 MM	7	07-08
DIE SET N. 8 - LENGTH 56 MM	8	08-09
DIE SET N. 9 - LENGTH 56 MM	9	09-10
DIE SET N. 10 - LENGTH 56 MM	10	10-12
DIE SET N. 12 - LENGTH 56 MM	12	12-15
DIE SET N. 14 - LENGTH 56 MM	14	14-15
DIE SET N. 15 - LENGTH 56 MM	15	15-18
DIE SET N. 17 - LENGTH 56 MM	17	17-18
DIE SET N. 18 - LENGTH 56 MM	18	18-21
DIE SET N. 20 - LENGTH 56 MM	20	17-18
DIE SET N. 21 - LENGTH 56 MM	21	21-24
DIE SET N. 24 - LENGTH 70 MM	24	24-27
DIE SET N. 27 - LENGTH 90 MM	27	27-30
DIE SET N. 30 - LENGTH 90 MM	30	30-33
DIE SET N. 33 - LENGTH 90 MM	33	33-36
DIE SET N. 36 - LENGTH 90 MM	36	36-39
DIE SET N. 39 - LENGTH 90 MM	39	39-42
DIE SET N. 42 - LENGTH 90 MM	42	42-45
DIE SET N. 45 - LENGTH 100 MM	45	45-48
DIE SET N. 48 - LENGTH 100 MM	48	48-51
DIE SET N. 51 - LENGTH 100 MM	51	51-57
DIE SET N. 54 - LENGTH 100 MM	54	54-57
DIE SET N. 57 - LENGTH 100 MM	57	57-62
DIE SET N. 60 - LENGTH 100 MM	60	60-62
DIE SET N. 62 - LENGTH 100 MM	62	62-66
DIE SET N. 66 - LENGTH 100 MM	66	66-70
DIE SET N. 70 - LENGTH 100 MM	70	70-72
DIE SET N. 72 - LENGTH 100 MM	72	72-80
KIT 9 DIES MV240 (N.15 TO N.51)	-	-
KIT 11 DIES MV240 (N.15 TO N.66)	-	-
KIT 12 DIES MV240 (N.15 TO N.66)	-	-
KIT 17 DIES MV240 (N.15 TO N.70)	-	-

DESCRIPTION	N°	CRIMP RANGE
DIE SET N. 4 - LENGTH 56 MM	4	04-05
DIE SET N. 6 - LENGTH 56 MM	6	06-08
DIE SET N. 7 - LENGTH 56 MM	7	07-08
DIE SET N. 8 - LENGTH 56 MM	8	08-09
DIE SET N. 9 - LENGTH 56 MM	9	09-10
DIE SET N. 10 - LENGTH 56 MM	10	10-12
DIE SET N. 12 - LENGTH 56 MM	12	12-15
DIE SET N. 15 - LENGTH 56 MM	15	15-18
DIE SET N. 18 - LENGTH 56 MM	18	18-21
DIE SET N. 21 - LENGTH 56 MM	21	21-24
DIE SET N. 24 - LENGTH 70 MM	24	24-27
DIE SET N. 27 - LENGTH 90 MM	27	27-30
DIE SET N. 30 - LENGTH 90 MM	30	30-33
DIE SET N. 33 - LENGTH 90 MM	33	33-36
DIE SET N. 36 - LENGTH 90 MM	36	36-39
DIE SET N. 39 - LENGTH 90 MM	39	39-42
DIE SET N. 42 - LENGTH 90 MM	42	42-45
DIE SET N. 45 - LENGTH 100 MM	45	45-48
DIE SET N. 48 - LENGTH 100 MM	48	48-51
DIE SET N. 51 - LENGTH 100 MM	51	51-57
DIE SET N. 54 - LENGTH 100 MM	54	54-57
DIE SET N. 57 - LENGTH 100 MM	57	57-62
DIE SET N. 62 - LENGTH 100 MM	62	62-66
DIE SET N. 66 - LENGTH 100 MM	66	66-70
DIE SET N. 70 - LENGTH 100 MM	70	70-72
KIT 9 DIES MV240L (N.15 TO N.51)	-	-
KIT 11 DIES MV240L (N.15 TO N.66)	-	-
KIT 12 DIES MV240L (N.15 TO N.66)	-	-
KIT 17 DIES MV240L (N.15 TO N.70)	-	-

DESCRIPTION	N°	CRIMP RANGE
DIE SET N. 4 - LENGTH 56 MM	4	04-05
DIE SET N. 6 - LENGTH 56 MM	6	06-08
DIE SET N. 7 - LENGTH 56 MM	7	07-08
DIE SET N. 8 - LENGTH 56 MM	8	08-09
DIE SET N. 9 - LENGTH 56 MM	9	09-10
DIE SET N. 10 - LENGTH 56 MM	10	10-12
DIE SET N. 12 - LENGTH 56 MM	12	12-15
DIE SET N. 14 - LENGTH 56 MM	14	14-15
DIE SET N. 15 - LENGTH 56 MM	15	15-18
DIE SET N. 17 - LENGTH 56 MM	17	17-18
DIE SET N. 18 - LENGTH 56 MM	18	18-21
DIE SET N. 20 - LENGTH 56 MM	20	17-18
DIE SET N. 21 - LENGTH 56 MM	21	21-24
DIE SET N. 24 - LENGTH 70 MM	24	24-27
DIE SET N. 27 - LENGTH 90 MM	27	27-30
DIE SET N. 30 - LENGTH 90 MM	30	30-33
DIE SET N. 33 - LENGTH 90 MM	33	33-36
DIE SET N. 36 - LENGTH 90 MM	36	36-39
DIE SET N. 39 - LENGTH 90 MM	39	39-42
DIE SET N. 42 - LENGTH 90 MM	42	42-45
DIE SET N. 45 - LENGTH 100 MM	45	45-48
DIE SET N. 48 - LENGTH 100 MM	48	48-51
DIE SET N. 51 - LENGTH 100 MM	51	51-57
DIE SET N. 54 - LENGTH 110 MM	54	54-57
DIE SET N. 57 - LENGTH 100 MM	57	57-62
DIE SET N. 54 - LENGTH 110 MM	54	54-57
DIE SET N. 62 - LENGTH 100 MM	62	62-66
DIE SET N. 66 - LENGTH 110 MM	66	66-70
DIE SET N. 70 - LENGTH 100 MM	70	70-72
DIE SET N. 73 - LENGTH 125 MM	73	73-76
DIE SET N. 75 - LENGTH 125 MM	75	75-76
DIE SET N. 76 - LENGTH 125 MM	76	76-86
DIE SET N. 80 - LENGTH 125 MM	80	80-86
DIE SET N. 86 - LENGTH 125 MM	86	86-90
DIE SET N. 90 - LENGTH 125 MM	90	90-95
DIE SET N. 95 - LENGTH 125 MM	95	95-105
DIE SET N. 99 - LENGTH 125 MM	99	99-109
DIE SET N. 112 - LENGTH 125 MM	112	112-117
DIE SET N. 117 - LENGTH 125 MM	117	117-122
DIE SET N. 122 - LENGTH 125 MM	122	122-127
KIT 12 DIES MV350 (N.15 TO N.66)	-	-
KIT 17 DIES MV350 (N.15 TO N.70)	-	-

DESCRIPTION	N°	CRIMP RANGE
DIE SET N. 4 - LENGTH 56 MM	4	04-05
DIE SET N. 6 - LENGTH 56 MM	6	06-08
DIE SET N. 7 - LENGTH 56 MM	7	07-08
DIE SET N. 8 - LENGTH 56 MM	8	08-09
DIE SET N. 9 - LENGTH 56 MM	9	09-10
DIE SET N. 10 - LENGTH 56 MM	10	10-12
DIE SET N. 12 - LENGTH 56 MM	12	12-15
DIE SET N. 14 - LENGTH 56 MM	14	14-15
DIE SET N. 15 - LENGTH 56 MM	15	15-18
DIE SET N. 17 - LENGTH 56 MM	17	17-18
DIE SET N. 18 - LENGTH 56 MM	18	18-21
DIE SET N. 20 - LENGTH 56 MM	20	17-18
DIE SET N. 21 - LENGTH 56 MM	21	21-24
DIE SET N. 24 - LENGTH 70 MM	24	24-27
DIE SET N. 27 - LENGTH 90 MM	27	27-30
DIE SET N. 30 - LENGTH 90 MM	30	30-33
DIE SET N. 33 - LENGTH 90 MM	33	33-36
DIE SET N. 36 - LENGTH 90 MM	36	36-39
DIE SET N. 39 - LENGTH 90 MM	39	39-42
DIE SET N. 42 - LENGTH 90 MM	42	42-45
DIE SET N. 45 - LENGTH 100 MM	45	45-48
DIE SET N. 48 - LENGTH 100 MM	48	48-51
DIE SET N. 51 - LENGTH 100 MM	51	51-57
DIE SET N. 54 - LENGTH 110 MM	54	54-57
DIE SET N. 57 - LENGTH 100 MM	57	57-62
DIE SET N. 54 - LENGTH 110 MM	54	54-57
DIE SET N. 62 - LENGTH 100 MM	62	62-66
DIE SET N. 66 - LENGTH 110 MM	66	66-70
DIE SET N. 70 - LENGTH 100 MM	70	70-72
DIE SET N. 73 - LENGTH 125 MM	73	73-76
DIE SET N. 75 - LENGTH 125 MM	75	75-76
DIE SET N. 76 - LENGTH 125 MM	76	76-86
DIE SET N. 80 - LENGTH 125 MM	80	80-86
DIE SET N. 86 - LENGTH 125 MM	86	86-90
DIE SET N. 90 - LENGTH 125 MM	90	90-95
DIE SET N. 95 - LENGTH 125 MM	95	95-105
DIE SET N. 99 - LENGTH 125 MM	99	99-109
DIE SET N. 112 - LENGTH 125 MM	112	112-117
DIE SET N. 117 - LENGTH 125 MM	117	117-122
DIE SET N. 122 - LENGTH 125 MM	122	122-127
KIT 12 DIES MV350L (N.15 TO N.66)	-	-
KIT 17 DIES MV350L (N.15 TO N.70)	-	-

MS 140

PG.570

DESCRIPTION	N°	CRIMP RANGE
DIE SET N. 4 - LENGTH 56 MM	4	04-05
DIE SET N. 6 - LENGTH 56 MM	6	06-08
DIE SET N. 7 - LENGTH 56 MM	7	07-08
DIE SET N. 8 - LENGTH 56 MM	8	08-09
DIE SET N. 9 - LENGTH 56 MM	9	09-10
DIE SET N. 10 - LENGTH 56 MM	10	10-12
DIE SET N. 12 - LENGTH 70 MM	12	12-15
DIE SET N. 14 - LENGTH 70 MM	14	14-15
DIE SET N. 15 - LENGTH 70 MM	15	15-18
DIE SET N. 17 - LENGTH 70 MM	17	17-18
DIE SET N. 18 - LENGTH 70 MM	18	18-21
DIE SET N. 20 - LENGTH 70 MM	20	20-21
DIE SET N. 21 - LENGTH 70 MM	21	21-24
DIE SET N. 24 - LENGTH 70 MM	24	24-27
DIE SET N. 27 - LENGTH 70 MM	27	27-30
DIE SET N. 30 - LENGTH 70 MM	30	30-33
DIE SET N. 33 - LENGTH 70 MM	33	33-36
DIE SET N. 36 - LENGTH 75 MM	36	36-39
DIE SET N. 39 - LENGTH 70 MM	39	39-42
DIE SET N. 42 - LENGTH 70-28 MM	42	42-45
DIE SET N. 45 - LENGTH 70 MM	45	45-48
DIE SET N. 48 - LENGTH 70 MM	48	48-51
DIE SET N. 51 - LENGTH 75 MM	51	51-57
KIT 10 DIES MS140 (N.15 TO N.48)	-	-
KIT 12 DIES MS140 (N.15 TO N.48)	-	-

DESCRIPTION	N°	CRIMP RANGE
DIE SET N. 4 - LENGTH 56 MM	4	04-05
DIE SET N. 6 - LENGTH 56 MM	6	06-08
DIE SET N. 7 - LENGTH 56 MM	7	07-08
DIE SET N. 8 - LENGTH 56 MM	8	08-09
DIE SET N. 10 - LENGTH 90 MM	10	10-12
DIE SET N. 12 - LENGTH 90 MM	12	12-15
DIE SET N. 14 - LENGTH 90 MM	14	14-15
DIE SET N. 15 - LENGTH 70 MM	15	15-18
DIE SET N. 17 - LENGTH 90 MM	17	17-18
DIE SET N. 18 - LENGTH 70 MM	18	18-21
DIE SET N. 20 - LENGTH 90 MM	20	20-21
DIE SET N. 21 - LENGTH 90 MM	21	21-24
DIE SET N. 24 - LENGTH 90 MM	24	24-27
DIE SET N. 27 - LENGTH 90 MM	27	27-30
DIE SET N. 30 - LENGTH 90 MM	30	30-33
DIE SET N. 33 - LENGTH 90 MM	33	33-36
DIE SET N. 36 - LENGTH 90 MM	36	36-39
DIE SET N. 39 - LENGTH 90 MM	39	39-42
DIE SET N. 42 - LENGTH 90 MM	42	42-45
DIE SET N. 45 - LENGTH 95 MM	45	45-48
DIE SET N. 48 - LENGTH 100 MM	48	48-51
DIE SET N. 51 - LENGTH 100 MM	51	51-57
DIE SET N. 54 - LENGTH 100 MM	54	54-57
DIE SET N. 57 - LENGTH 100 MM	57	57-62
DIE SET N. 60 - LENGTH 100 MM	60	60-62
DIE SET N. 62 - LENGTH 110 MM	62	62-66
DIE SET N. 62 - LENGTH 125 MM	62	62-66
DIE SET N. 66 - LENGTH 100 MM	66	66-70
DIE SET N. 66 - LENGTH 125 MM	66	66-70
DIE SET N. 70 - LENGTH 100 MM	70	70-72
DIE SET N. 70 - LENGTH 125 MM	70	70-72
DIE SET N. 73 - LENGTH 120 MM	73	73-76
DIE SET N. 76 - LENGTH 120 MM	76	76-86
DIE SET N. 80 - LENGTH 100 MM	80	80-86
DIE SET N. 86 - LENGTH 100-65 MM	86	86-90
DIE SET N. 90 - LENGTH 100 MM, REINFORCED PIN	90	90-95
DIE SET N. 95 - LENGTH 100 MM, REINFORCED PIN	95	95-105
DIE SET N. 99 - LENGTH 100 MM	99	99-109
DIE SET N. 112 - LENGTH 100 MM	112	112-117
DIE SET N. 117 - LENGTH 100 MM	117	117-122
DIE SET N. 122 - LENGTH 100 MM	122	122-127
KIT 13 DIES MS320 (N.15 TO N.73)	-	-
KIT 19 DIES MS320 (N.15 TO N.76)	-	-

DESCRIPTION	N°	CRIMP RANGE
DIE SET N. 4 - LENGTH 56 MM	4	04-05
DIE SET N. 6 - LENGTH 56 MM	6	06-08
DIE SET N. 7 - LENGTH 56 MM	7	07-08
DIE SET N. 8 - LENGTH 56 MM	8	08-09
DIE SET N. 10 - LENGTH 90 MM	10	10-12
DIE SET N. 12 - LENGTH 90 MM	12	12-15
DIE SET N. 14 - LENGTH 90 MM	14	14-15
DIE SET N. 15 - LENGTH 90 MM	15	15-18
DIE SET N. 17 - LENGTH 90 MM	17	17-18
DIE SET N. 18 - LENGTH 90 MM	18	18-21
DIE SET N. 20 - LENGTH 90 MM	20	20-21
DIE SET N. 21 - LENGTH 90 MM	21	21-24
DIE SET N. 24 - LENGTH 90 MM	24	24-27
DIE SET N. 27 - LENGTH 90 MM	27	27-30
DIE SET N. 30 - LENGTH 100 MM	30	30-33
DIE SET N. 33 - LENGTH 90 MM	33	33-36
DIE SET N. 36 - LENGTH 90 MM	36	36-39
DIE SET N. 39 - LENGTH 90 MM	39	39-42
DIE SET N. 42 - LENGTH 90 MM	42	42-45
DIE SET N. 45 - LENGTH 100 MM	45	45-48
DIE SET N. 48 - LENGTH 100 MM	48	48-51
DIE SET N. 51 - LENGTH 110 MM	51	51-57
DIE SET N. 54 - LENGTH 110 MM	54	54-57
DIE SET N. 57 - LENGTH 110 MM	57	57-62
DIE SET N. 60 - LENGTH 110 MM	60	60-62
DIE SET N. 62 - LENGTH 110 MM	62	62-66
DIE SET N. 62* - LENGTH 125 MM	62*	62-66
DIE SET N. 66 - LENGTH 110 MM	66	66-70
DIE SET N. 66* - LENGTH 125 MM	66*	66-70
DIE SET N. 70 - LENGTH 110 MM	70	70-72
DIE SET N. 70* - LENGTH 125 MM	70*	70-72
DIE SET N. 73 - LENGTH 125-28 MM, REINFORCED PIN	73	73-76
DIE SET N. 76 - LENGTH 135 MM	76	76-86
DIE SET N. 80 - LENGTH 125 MM	80	80-86
DIE SET N. 82 - LENGTH 135 MM	82	82-90
DIE SET N. 86 - LENGTH 150 MM	86	86-90
DIE SET N. 86 - LENGTH 125-48 MM	86	
DIE SET N. 90 - LENGTH 125 MM	90	90-95
DIE SET N. 95 - LENGTH 150 MM	95	95-105
DIE SET N. 95 - LENGTH 125-48 MM	95	
DIE SET N. 99 - LENGTH 125 MM, REINFORCED PIN	99	99-105
DIE SET N. 105 - LENGTH 150 MM	105	105-112
DIE SET N. 112 - LENGTH 150 MM	112	112-122
DIE SET N. 117 - LENGTH 125 MM	117	117-122
DIE SET N. 122 - LENGTH 130 MM, REINFORCED PIN	122	122 -130
DIE SET N. 130 - LENGTH 145 MM	130	130-140
KIT 13 DIES MS480 (N.15 TO N.73)	-	-
KIT 19 DIES MS480 (N.15 TO N.76)	-	-

DESCRIPTION	N°	CRIMP RANGE
DIE SET N. 4 - LENGTH 56 MM	4	04-05
DIE SET N. 6 - LENGTH 56 MM	6	06-08
DIE SET N. 7 - LENGTH 56 MM	7	07-08
DIE SET N. 8 - LENGTH 56 MM	8	08-09
DIE SET N. 10 - LENGTH 56 MM	10	10-12
DIE SET N. 12 - LENGTH 90 MM	12	12-15
DIE SET N. 15 - LENGTH 90 MM	15	15-18
DIE SET N. 17 - LENGTH 90 MM	17	17-18
DIE SET N. 18 - LENGTH 90 MM	18	18-21
DIE SET N. 20 - LENGTH 90 MM	20	20-21
DIE SET N. 21 - LENGTH 90 MM	21	21-24
DIE SET N. 24 - LENGTH 90 MM	24	24-27
DIE SET N. 27 - LENGTH 90 MM	27	27-30
DIE SET N. 30 - LENGTH 90 MM	30	30-33
DIE SET N. 33 - LENGTH 90 MM	33	33-36
DIE SET N. 36 - LENGTH 90 MM	36	36-39
DIE SET N. 39 - LENGTH 90 MM	39	39-42
DIE SET N. 42 - LENGTH 90 MM	42	42-45
DIE SET N. 45 - LENGTH 100 MM	45	45-48
DIE SET N. 48 - LENGTH 100 MM	48	48-51
DIE SET N. 51 - LENGTH 110 MM	51	51-57
DIE SET N. 54 - LENGTH 110 MM	54	54-57
DIE SET N. 57 - LENGTH 110 MM	57	57-62
DIE SET N. 60 - LENGTH 110 MM	60	60-62
DIE SET N. 62 - LENGTH 110 MM	62	62-66
DIE SET N. 62* - LENGTH 125 MM	62*	62-66
DIE SET N. 66 - LENGTH 110 MM	66	66-70
DIE SET N. 66* - LENGTH 125 MM	66*	66-70
DIE SET N. 70 - LENGTH 110 MM	70	70-72
DIE SET N. 70* - LENGTH 125 MM	70*	70-72
DIE SET N. 73 - LENGTH 125-28 MM, REINFORCED PIN	73	73-76
DIE SET N. 76 - LENGTH 125 MM	76	76-86
DIE SET N. 76* - LENGTH 135 MM	76*	76-86
DIE SET N. 80 - LENGTH 125 MM	80	80-86
DIE SET N. 82 - LENGTH 135 MM	82	82-90
DIE SET N. 86 - LENGTH 150 MM	86	86-90
DIE SET N. 90 - LENGTH 125 MM	90	90-95
DIE SET N. 95 - LENGTH 150 MM	95	95-105
DIE SET N. 105 - LENGTH 180 MM	105	105-112
DIE SET N. 112 - LENGTH 150 MM	112	112-122
DIE SET N. 130 - LENGTH 180 MM	130	130-140
KIT 13 DIES MS800 (N.15 TO N.73)	-	-
KIT 18 DIES MS800 (N.39 TO N.130)	-	-

DESCRIPTION	N°	CRIMP RANGE
DIE SET N. 73 - LENGTH 125 MM	73	73-80
DIE SET N. 80 - LENGTH 125 MM	80	80-86
DIE SET N. 84 - LENGTH 125 MM	84	86-90
DIE SET N. 86 - LENGTH 125 MM	86	86-90
DIE SET N. 90 - LENGTH 125 MM	90	90-95
DIE SET N. 95 - LENGTH 125 MM	95	95-105
DIE SET N. 99 - LENGTH 125 MM	99	99-106
DIE SET N. 106 - LENGTH 125 MM	106	106-112
DIE SET N. 112 - LENGTH 125 MM	112	112-117
DIE SET N. 117 - LENGTH 125 MM	117	117-122
DIE SET N. 122 - LENGTH 125 MM	122	122-125
DIE SET N.125 - LENGTH 125 MM	125	125-128
DIE SET N. 128 - LENGTH 125 MM	128	128-130
DIE SET N. 130 - LENGTH 125 MM	130	130-140
DIE SET N. 135 - LENGTH 125 MM	135	135-145
DIE SET N. 150 - LENGTH 125 MM	150	150-160
DIE SET N. 156 - LENGTH 125 MM	156	156-166
DIE SET N. 158 - LENGTH 125 MM	158	158-168
DIE SET N. 165 - LENGTH 125 MM	165	165-185
DIE SET N. 175 - LENGTH 125 MM	175	175-195
DIE SET N. 181 - LENGTH 125 MM	181	181-201
DIE SET N. 185 - LENGTH 125 MM	185	185-205
DIE SET N. 188 - LENGTH 125 MM	188	188-208
DIE SET N. 190 - LENGTH 125 MM	190	190-210

- OTHER DIMENSIONS UPON REQUEST

DESCRIPTION	N°	CRIMP RANGE
DIE SET N. 4 - LENGTH 56 MM	4	04-05
DIE SET N. 6 - LENGTH 56 MM	6	06-08
DIE SET N. 7 - LENGTH 56 MM	7	07-08
DIE SET N. 8 - LENGTH 56 MM	8	08-09
DIE SET N. 10 - LENGTH 56 MM	10	10-12
DIE SET N. 12 - LENGTH 56 MM	12	12-15
DIE SET N. 15 - LENGTH 56 MM	15	15-18
DIE SET N. 17 - LENGTH 56 MM	17	17-18
DIE SET N. 18 - LENGTH 56 MM	18	18-21
DIE SET N. 20 - LENGTH 56 MM	20	20-21
DIE SET N. 21 - LENGTH 56 MM	21	21-24
DIE SET N. 24 - LENGTH 70 MM	24	24-27
DIE SET N. 27 - LENGTH 90 MM	27	27-30
DIE SET N. 30 - LENGTH 90 MM	30	30-33
DIE SET N. 33 - LENGTH 90 MM	33	33-36
DIE SET N. 36 - LENGTH 90 MM	36	36-39
DIE SET N. 39 - LENGTH 90 MM	39	39-42
DIE SET N. 42 - LENGTH 90 MM	42	42-45
DIE SET N. 45 - LENGTH 100 MM	45	45-48
DIE SET N. 48 - LENGTH 100 MM	48	48-51
DIE SET N. 51 - LENGTH 110 MM	51	51-57
DIE SET N. 54 - LENGTH 110 MM	54	54-57
DIE SET N. 57 - LENGTH 110 MM	57	57-62
DIE SET N. 60 - LENGTH 110 MM	60	60-62
DIE SET N. 62 - LENGTH 110 MM	62	62-66
DIE SET N. 62* - LENGTH 125 MM	62*	62-66
DIE SET N. 66 - LENGTH 110 MM	66	66-70
DIE SET N. 66* - LENGTH 125 MM	66*	66-70
DIE SET N. 70 - LENGTH 100 MM	70	70-72
DIE SET N. 70* - LENGTH 125 MM	70*	70-72
DIE SET N. 73 - LENGTH 125-28 MM, REINFORCED PIN	73	73-76
DIE SET N. 76 - LENGTH 125 MM	76	76-86
DIE SET N. 76* - LENGTH 135 MM	76*	76-86
DIE SET N. 80 - LENGTH 125 MM	80	80-82
DIE SET N. 82 - LENGTH 135 MM	82	82-90
DIE SET N. 86* - LENGTH 150 MM (FOR DIAMONDSPIR 2½")	86*	86-90
DIE SET N. 90 - LENGTH 125 MM	90	90-95
DIE SET N. 95 - LENGTH 150 MM (FOR DIAMONDSPIR 2½")	95*	95-105
DIE SET N. 99 - LENGTH 125 MM	99	95-105
DIE SET N. 105 - LENGTH 150 MM	105	99-109
DIE SET N. 112 - LENGTH 150 MM	112	112-122
DIE SET N. 117 - LENGTH 110 MM	117	117-127
DIE SET N. 122 - LENGTH 130 MM, REINFORCED PIN	122	122-130
KIT 13 DIE SET XLCRIMP450-200 (15 TO 73)	-	-
KIT 19 DIE SET XLCRIMP450-200(15 TO 76)	-	-

- OTHER DIMENSIONS UPON REQUEST

DESCRIPTION	N°	CRIMP RANGE
DIE SET N. 73 - LENGTH 125 MM	73	73-80
DIE SET N. 80 - LENGTH 125 MM	80	80-86
DIE SET N. 86 - LENGTH 125 MM	86	86-90
DIE SET N. 90 - LENGTH 125 MM	90	90-95
DIE SET N. 95 - LENGTH 125 MM	95	95-105
DIE SET N. 99 - LENGTH 125 MM	99	99-112
DIE SET N. 112 - LENGTH 125 MM	112	112-117
DIE SET N. 117 - LENGTH 125 MM	117	117-122
DIE SET N. 122 - LENGTH 125 MM	122	122-130
DIE SET N. 130 - LENGTH 200 MM	130	130-140
DIE SET N. 140 - LENGTH 200 MM	140	140-150
DIE SET N. 150 - LENGTH 200 MM	150	150-160
DIE SET N. 156 - LENGTH 200 MM	156	156-166
DIE SET N. 160 - LENGTH 200 MM	160	160-180
DIE SET N. 165 - LENGTH 200 MM	165	165-185
DIE SET N. 170 - LENGTH 200 MM	170	170-190
DIE SET N. 176 - LENGTH 200 MM	176	176-196
DIE SET N. 178 - LENGTH 200 MM	178	178-198
DIE SET N. 180 - LENGTH 200 MM	180	180-200
DIE SET N. 200 - LENGTH 200 MM	200	200-220
DIE SET N. 215 - LENGTH 200 MM	215	215-235
DIE SET N. 225 - LENGTH 200 MM	225	225-245
DIE SET N. 230 - LENGTH 200 MM	230	230-250
DIE SET N. 235 - LENGTH 200 MM	235	235-255
DIE SET N. 250 - LENGTH 200 MM	250	250-270
DIE SET N. 260 - LENGTH 200 MM	260	260-280
DIE SET N. 265 - LENGTH 200 MM	265	265-285
DIE SET N. 280 - LENGTH 200 MM	280	280-300
DIE SET N. 282 - LENGTH 200 MM	282	282-302
DIE SET N. 285 - LENGTH 200 MM	285	285-305
DIE SET N. 290 - LENGTH 200 MM	290	290-310
DIE SET N. 308 - LENGTH 200 MM	308	308-328
DIE SET N. 317 - LENGTH 200 MM	317	317-337
DIE SET N. 330 - LENGTH 200 MM	330	330-350
DIE SET N. 340 - LENGTH 200 MM	340	340-360

- OTHER DIMENSIONS UPON REQUEST

