

FLUSHFIT COUPLINGS

The Manuli Hydraulics range of Flushfit connectors provides a unique solution where the staple is located within the envelope of the assembly.

This sleek design enables a more compact and efficient means of making hydraulic connections and installing hose pressure lines, whilst actively minimising the risk of hose abrasion due to contact with the staple.

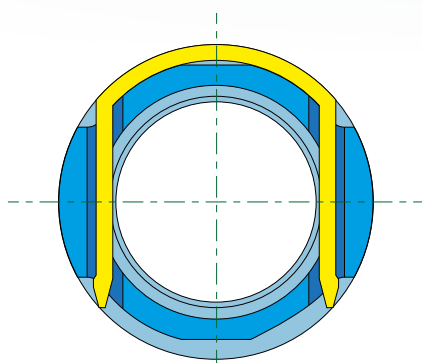

Cross-section of a Flushfit fitting with staple in-situ

KEY BENEFITS

- Increased strength and performance
- Snag-free profile
- Minimises hose damage and abrasion
- Large bore XXL size range
- Reduces handling / installation time

	Range	Dash	Inches	DN	W.P. (bar)	W.P. (psi)
Low Pressure Return Lines	SA Flushfit (SAF)	16	1	25	350	5,000
		24	1½	38	185	2,683
		32	2	51	112	1,624
		40	2½	63	140	2,030
	SA Flushfit PLUS (SAFP)	48	3	76	105	1,523
		56	3½	89	105	1,523
SA Flushfit PLUS XTRA (SAFPX)	48	3	76	140	2,030	
High Pressure Feed Lines	SH Flushfit & Sliderlock (SHF & SLH)	24	1½	38	420	6,000
		32	2	51	420	6,000
		40	2½	63	350	5,000
		48	3	76	350	5,000